



26H

Automatic Icemaker

**AUTOMATIC
ICEMAKER**

**INSTALLATION
AND
SERVICE
INFORMATION**

Specifications

page 3

Dimension Drawings

page 7

Installation Instructions

page 9

Service Instructions

page 19

Service Parts

page 63



CONTENTS

26H

CARRIER AUTOMATIC ICEMAKER

	PAGES
SPECIFICATIONS.....	3-6
DIMENSION DRAWINGS.....	7, 8
INSTALLATION.....	9-18
1. Check Shipment.....	9
2. Select Proper Location.....	9
3. Move Unit to Location.....	9
4. Uncrate the Bin.....	10
5. Install Leveling Screws.....	10
6. Unpack and Mount the Heat Interchanger.....	10
7. Move the Bin to Approximate Location.....	11
8. Uncrate the Machine Section.....	11
9. Remove the Front, Top and Side Panels.....	11
10. Place Machine Section on Top of Bin and Bolt in Position.....	11
11. Bolt Tie Bar at Rear of Unit.....	12
12. Install Water Supply and Drains.....	12
13. Make Electrical Connections.....	13
14. Install Bin Thermostat Bulb.....	14
15. Remove the Ice Deflector.....	14
16. Install Siphon Standpipe and Adjust Float.....	14
17. Replace the Ice Deflector.....	15
18. Loosen Compressor Hold Down Bolts.....	16
19. Start the Unit.....	16
20. Check Operation.....	17
21. Final Check List.....	17
SERVICE.....	19-61
1. How the Automatic Ice Maker Works.....	19
2. Refrigerant Circuit.....	23
3. Freezing Water Circuit.....	36
4. Electrical Circuit.....	40
5. Ice Maker Service Check List.....	53
6. Service Analysis 26H5 and 26H3.....	54
7. 26H Icemaker Rating Tables.....	60
SERVICE PARTS.....	63-64

All specifications, descriptions, detail drawings, etc.
subject to change without notice or incurring obligation.

Litho in U.S.A

1st Printing 7-15-57 5M

1st Reprint 5-15-58 2M



Automatic Icemaker

26H3

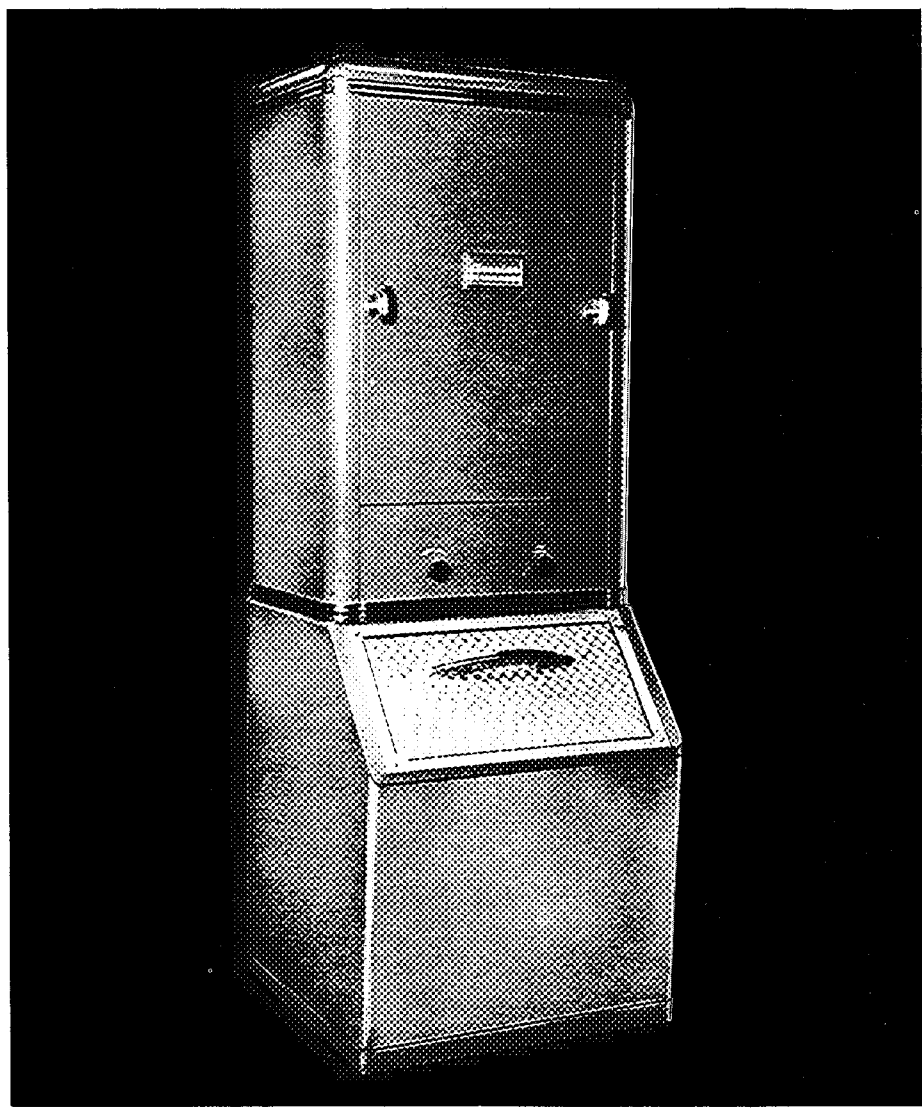

An automatic, low-cost ICE PLANT . . . right in your PLACE of BUSINESS!

- Produces a continuous supply of ice, cubed or crushed, automatically.
- Cubes are crystal clear, sanitary . . . untouched by human hands. Cube's unique shape provides larger cooling surface.
- Crushed ice delivered in three grades . . . to meet all your sized-ice needs.
- Easily, quickly installed. Requires only standard electrical and water connections.
- Re-location a simple matter. Just disconnect water and electricity . . . reinstall in new location.
- Compact cabinet occupies only 4 sq. ft. floor area.
- Exterior styled to blend with finest surroundings. Finished in sea spray green or white, stainless steel trim.
- Minimum maintenance, maximum quietness . . . simplified, unique mechanism delivers individually formed cubes.
- Starts with simple on-off switch. Machine stops automatically when bin is full, resumes operation as soon as few cubes are removed.
- Low operating cost . . . efficient, quiet refrigeration cycle uses small amounts of water and power.

• Underwriters approved.

IDEAL for RESTAURANTS, HOTELS, MOTELS, BARS, TAVERNS, CLUBS, HOSPITALS, DRUG STORES . . . wherever a continuous supply of clear, sanitary ice, cubed or crushed, is a tangible business asset. The Carrier Icemaker freezes and delivers up to 200 pounds of ice per day, at 90° ambient air and 70° entering water. Quietly, without complicated cutting or chopping mechanism, it provides hard, sparkling cubes or varied grades of crushed ice. The cube, too, is designed for highest efficiency . . . its unique shape provides more-than-ordinary cooling surface.

COMPACT, ATTRACTIVE CABINET . . . takes up only 4 square feet of floor area. Smart, modern design, featuring rounded corners, a bonderized, baked-on sea spray green or white finish, richly trimmed in stainless steel and chrome . . . complements any and all furnishings.

ICE CRUSHER. Entirely automatic, electric-motor driven unit. Delivers crushed ice in three grades—coarse, medium, or fine. User sets one control knob to "crushed" and the other to grade as dictated by needs.

REMOVABLE PANELS provide easy access to working parts. Access for all normal service through removable front panel.

WELDED-TYPE HERMETIC COMPRESSOR. Quiet, efficient, permanently oiled and vibrationless. Designed for long life and trouble-free operation.

MECHANICAL SPECIFICATIONS

COMPRESSOR: ½ horsepower, single cylinder, welded-type, hermetic compressor, driven by a capacitor-start, induction-run motor.

CONDENSER: Water-cooled, shell and finned copper coil type.

REFRIGERANT: Safe, non-toxic, non-inflammable FREON-12.

REFRIGERANT CONTROL: Single capillary tube . . . no moving parts.

WATER PUMP: Stainless steel shaft, brass impeller and brass housing. Directly connected to a shaded pole, totally enclosed, thermally protected motor.

POWER CONSUMPTION: 575 watts during freezing.

SWITCH: 3-position rotary . . . for manual starting and stopping, or for operating of water pump for cleaning.

CURRENT: 115 volt, 60 cycle, single phase, alternating current.

EXCLUSIVE DESIGN ICE-MAKING SYSTEM. NO MOVING PARTS. Freezing coils are soldered to copper bands and attached, at 8 different points, to each of 13 stainless steel freezing tubes. In operation, ice builds up on inside wall of tube at these 8 separate points to form 8 cubes in each tube. Freezing completed, automatic controls reverse cycle, releasing cubes which simply "gravity drop" into bin or crusher, as "dialed" by user.

COMPLETELY AUTOMATIC. A simple rotary switch starts the machine, from then on it produces ice automatically. When storage bin fills with cubes, or crushed ice, the machine shuts off automatically, starting again whenever some ice is used.

STORAGE BIN (bottom section) available in four sizes — 100, 160, 240 and 500 pounds capacity. It has baked-on finish, stainless steel liner and 2 inches of insulation on sides. Partition separates cubes and crushed ice.

SIPHON-INTERCHANGER. Automatically replaces the water in the Icemaker system at the end of each freezing cycle. Pure, crystal clear ice is assured, even in hard water areas, with a minimum of cleaning and maximum productive capacity.

WATER CONSUMPTION: During freezing, 10 to 42 gallons per hour, depending upon supply water temperatures.

DIMENSIONS: 69 inches high, 25 inches deep. Width is 24 inches with 100 pound storage.

26H3 ICEMAKER WEIGHTS:

	Lbs.
Machine section, 100 lb. bin, no crusher, crated	348
Machine section, 100 lb. bin, no crusher, uncrated	305
Machine section, 100 lb. bin, with crusher, crated	388
Machine section, 100 lb. bin, with crusher, uncrated	345
Machine section, 160 lb. bin, no crusher, crated	371
Machine section, 160 lb. bin, no crusher, uncrated	326
Machine section, 160 lb. bin, with crusher, crated	411
Machine section, 160 lb. bin, with crusher, uncrated	366
Machine section, 240 lb. bin, no crusher, crated	405
Machine section, 240 lb. bin, no crusher, uncrated	357
Machine section, 240 lb. bin, with crusher, crated	445
Machine section, 240 lb. bin, with crusher, uncrated	397

ICE CRUSHER: Cast aluminum rotor, stainless steel picks, sleeve bearings, belt-driven by a 1/6 horsepower, drip-proof, thermally protected motor, with adjustable drive-pulley.



Automatic Icemaker

26H5

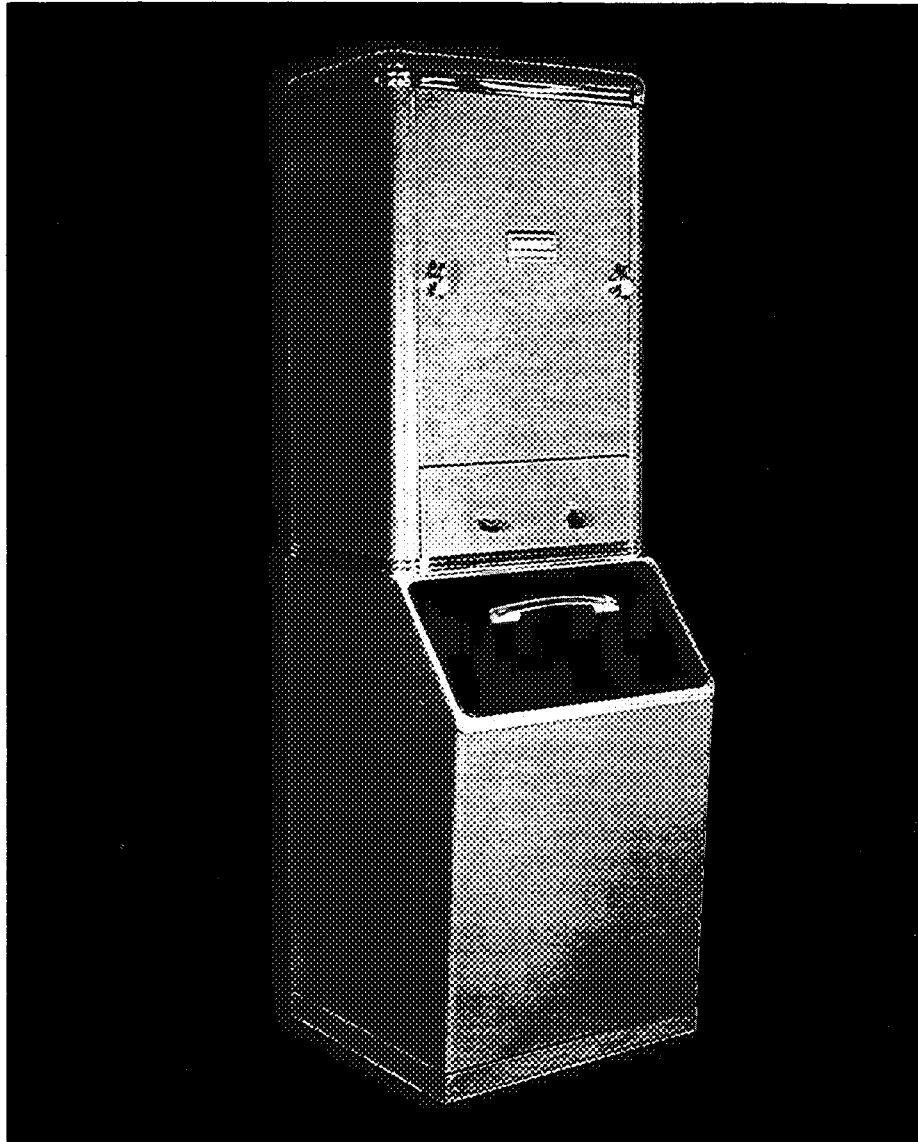

An automatic, low-cost ICE PLANT . . . right in your PLACE of BUSINESS!

- Produces a continuous supply of ice, cubed or crushed, automatically.
- Cubes are crystal clear, sanitary . . . untouched by human hands. Cube's unique shape provides larger cooling surface.
- Crushed ice delivered in three grades . . . to meet all your sized-ice needs.
- Easily, quickly installed. Requires only standard electrical and water connections.
- Re-location a simple matter. Just disconnect water and electricity . . . reinstall in new location.
- Compact cabinet occupies only 4 sq. ft. floor area.
- Exterior styled to blend with finest surroundings. Finished in sea spray green or white, stainless steel trim.
- Minimum maintenance, maximum quietness . . . simplified, unique mechanism delivers individually formed cubes.
- Starts with simple on-off switch. Machine stops automatically when bin is full, resumes operation as soon as few cubes are removed.
- Low operating cost . . . efficient, quiet refrigeration cycle uses small amounts of water and power.
- Underwriters approved.



IDEAL for RESTAURANTS, HOTELS, MOTELS, BARS, TAVERNS, CLUBS, HOSPITALS, DRUG STORES . . . wherever a continuous supply of clear, sanitary ice, cubed or crushed, is a tangible business asset. The Carrier Icemaker freezes and delivers up to 450 pounds of ice per day, at 90° ambient air and 70° entering water. Quietly, without complicated cutting or chopping mechanism, it provides hard, sparkling cubes or varied grades of crushed ice. The cube, too, is designed for highest efficiency . . . its unique shape provides more-than-ordinary cooling surface.

COMPACT, ATTRACTIVE CABINET . . . takes up only 4 square feet of floor area. Smart, modern design, featuring rounded corners, a bonderized, baked-on sea spray green or white finish, richly trimmed in stainless steel and chrome . . . complements any and all furnishings.

ICE CRUSHER. Entirely automatic, electric-motor driven unit. Delivers crushed ice in three grades — coarse, medium, or fine. User sets one control knob to "crushed" and the other to grade as dictated by needs.

REMOVABLE PANELS provide easy access to working parts. Access for all normal service through removable front panel.

CARRIER SERVICEABLE-HERMETIC COMPRESSOR. Provides all the advantages of ordinary, welded-type, hermetically sealed compressors. No oiling, no belts, no shaft seal with consequent risk of refrigerant loss. In addition, retaining the advantages of the open-type compressor — can be adjusted and serviced on the job.

MECHANICAL SPECIFICATIONS

COMPRESSOR: ¾-horsepower, twin-cylinder, serviceable hermetic type with a capacitor-start, induction-run, low starting torque motor.

CONDENSER: Water-cooled, shell and finned copper coil type.

REFRIGERANT: Safe, non-toxic, non-inflammable FREON-12.

REFRIGERANT CONTROL: Twin capillary tubes . . . no moving parts.

WATER PUMP: Stainless steel shaft, bronze impeller and bronze housing. Directly connected to a shaded pole, totally enclosed, thermally protected motor.

POWER CONSUMPTION: 940 watts during freezing.

SWITCH: 3-position rotary . . . for manual starting and stopping, or for operating of water pump for cleaning.

CURRENT: Available for 115 volt, 208 volt (with conversion package), or 230 volt, 60 cycle, single phase, alternating current.

EXCLUSIVE DESIGN ICE-MAKING SYSTEM. NO MOVING PARTS. Freezing coils are soldered to copper bands and attached, at 8 different points, to each of 26 stainless steel freezing tubes. In operation, ice builds up on inside wall of tube at these 8 separate points to form 8 cubes in each tube. Freezing completed, automatic controls reverse cycle, releasing cubes which simply "gravity drop" into bin or crusher, as "dialed" by user.

COMPLETELY AUTOMATIC. A simple rotary switch starts the machine, from then on it produces ice automatically. When storage bin fills with cubes, or crushed ice, the machine shuts off automatically, starting again whenever some ice is used.

STORAGE BIN (bottom section) available in three sizes — 160 pounds, 240 pounds and 500 pounds capacity. It has baked-on finish, stainless steel liner, 2 inches of insulation. Partition separates cubes and crushed ice.

SIPHON-INTERCHANGER. Automatically replaces the water in the Icemaker system at the end of each freezing cycle. Pure, crystal clear ice is assured, even in hard water areas, with a minimum of cleaning and maximum productive capacity.

ACCESSORY

208-VOLT CONVERSION PACKAGE. Consists of a transformer which permits 230-volt model to operate satisfactorily on 208 volts.

WATER CONSUMPTION: During freezing, 15 to 70 gallons per hour, depending upon supply water temperatures.

DIMENSIONS: 77 inches high, 25 inches deep. Width is 24 inches for 160 pound storage model, 34 inches for 240 pound model.

26H5 ICEMAKER WEIGHTS:

	Lbs.
Machine section, 160 lb. bin, no crusher, crated	450
Machine section, 160 lb. bin, no crusher, uncrated	405
Machine section, 160 lb. bin, with crusher, crated	490
Machine section, 160 lb. bin, with crusher, uncrated	445
Machine section, 240 lb. bin, no crusher, crated	484
Machine section, 240 lb. bin, no crusher, uncrated	436
Machine section, 240 lb. bin, with crusher, crated	524
Machine section, 240 lb. bin, with crusher, uncrated	476
Machine section, 500 lb. bin, no crusher, uncrated	438
Machine section, 500 lb. bin, with crusher, uncrated	478

ICE CRUSHER: Cast aluminum rotor, stainless steel picks, sleeve bearings, belt-driven by a 1/6 horsepower, drip-proof, thermally protected motor, with adjustable drive-pulley.



DIMENSIONS

26H

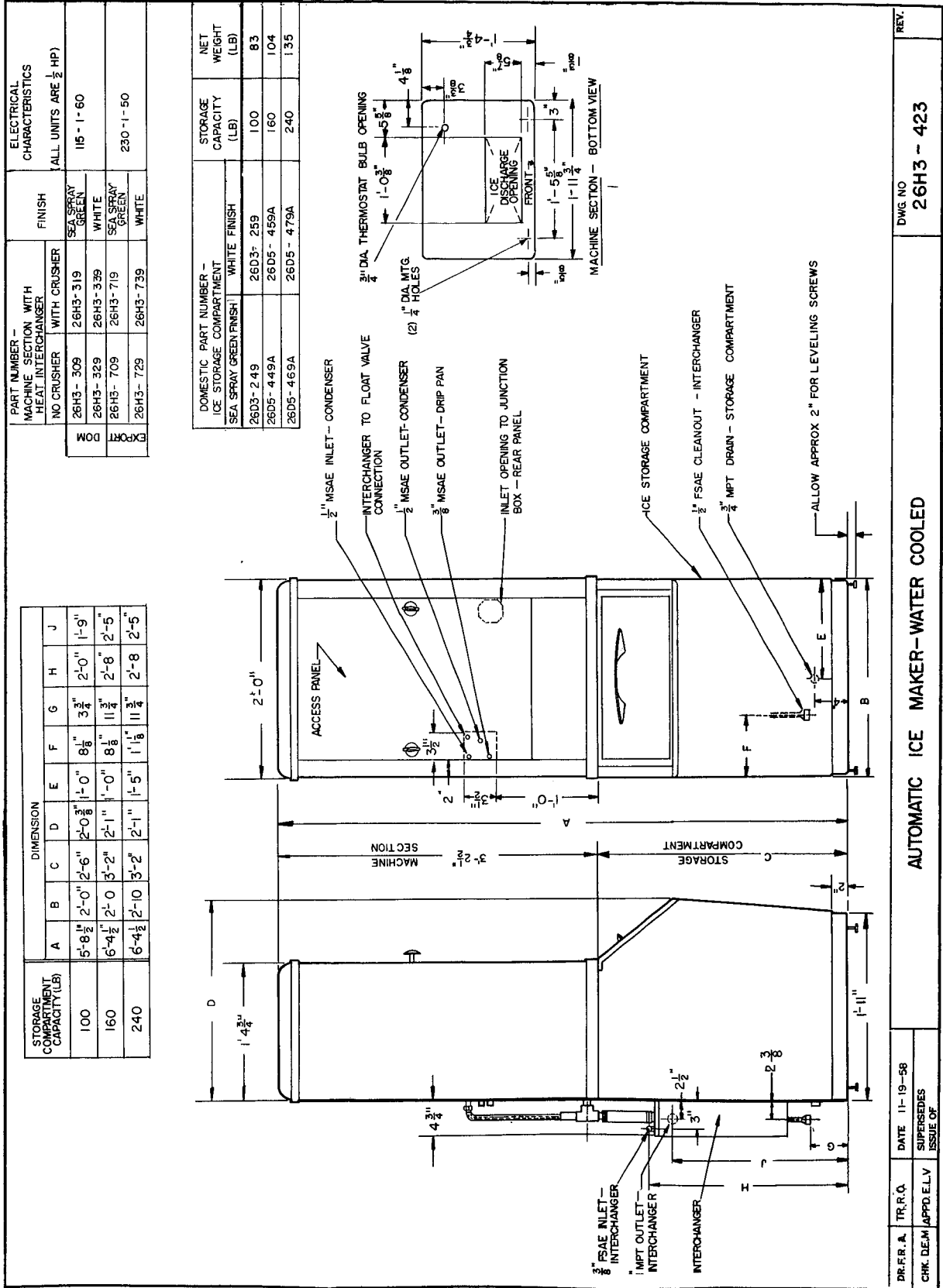

AUTOMATIC ICE MAKER - WATER COOLED

DWG NO
26H3 - 423

REV.

DR. F. R. TR. R. Q. DATE 11-19-58
CHK. D. E. M. APP. D. L. V. SUPERSEDES
ISSUE OF

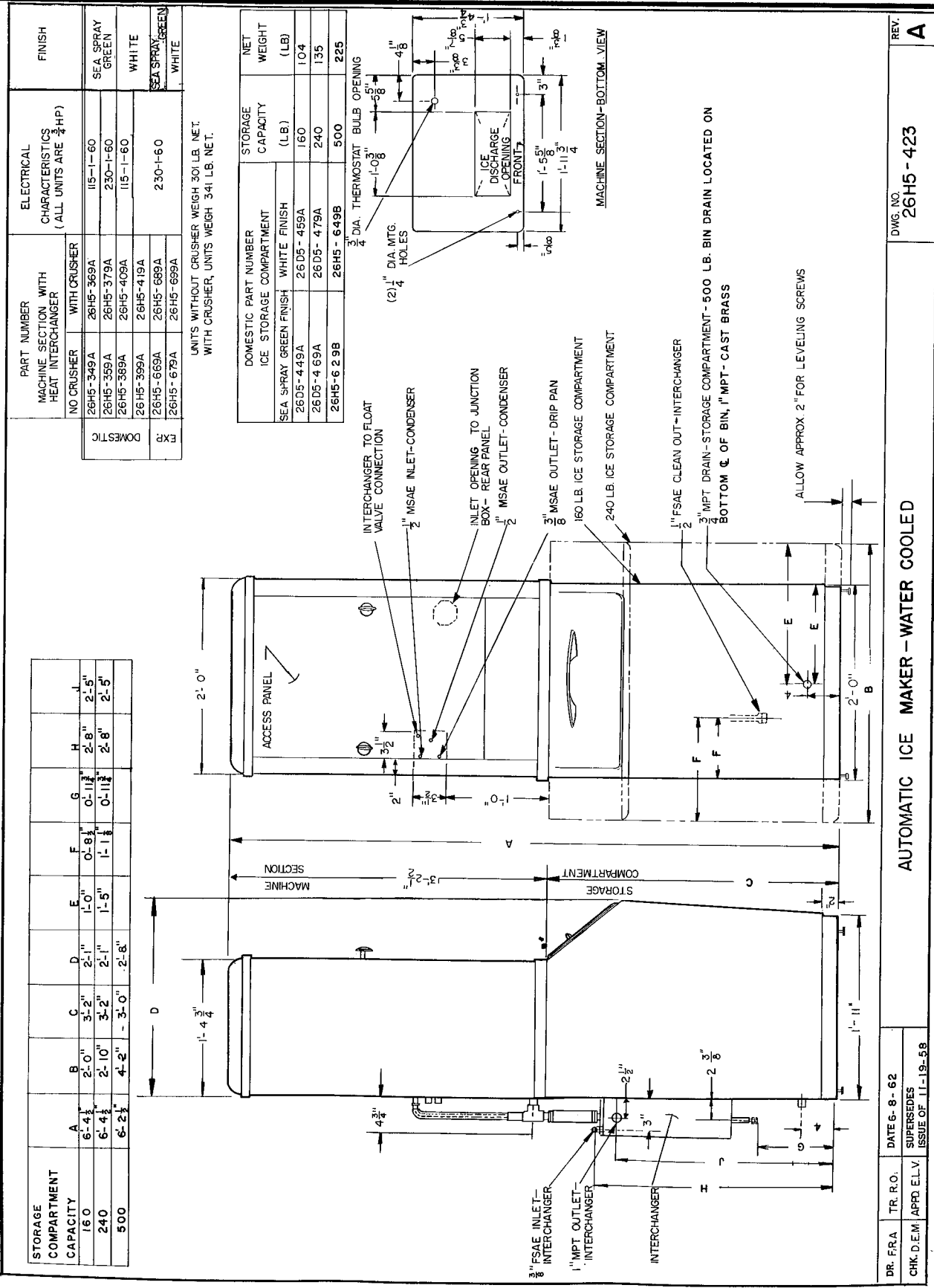

DOMESTIC PART NUMBER	ICE STORAGE COMPARTMENT	WHITE FINISH	NET WEIGHT (LB)
26H5-349A	26H5-369A	26H5-379A	104
26H5-359A	26H5-379A	26H5-389A	135
26H5-369A	26H5-389A	26H5-399A	225
26H5-379A	26H5-399A	26H5-409A	
26H5-389A	26H5-409A	26H5-419A	
26H5-399A	26H5-419A	26H5-429A	
26H5-409A	26H5-429A	26H5-439A	
26H5-419A	26H5-439A	26H5-449A	
26H5-429A	26H5-449A	26H5-459A	
26H5-439A	26H5-459A	26H5-469A	
26H5-449A	26H5-469A	26H5-479A	
26H5-459A	26H5-479A	26H5-489A	
26H5-469A	26H5-489A	26H5-499A	
26H5-479A	26H5-499A	26H5-509A	
26H5-489A	26H5-509A	26H5-519A	
26H5-499A	26H5-519A	26H5-529A	
26H5-509A	26H5-529A	26H5-539A	
26H5-519A	26H5-539A	26H5-549A	
26H5-529A	26H5-549A	26H5-559A	
26H5-539A	26H5-559A	26H5-569A	
26H5-549A	26H5-569A	26H5-579A	
26H5-559A	26H5-579A	26H5-589A	
26H5-569A	26H5-589A	26H5-599A	
26H5-579A	26H5-599A	26H5-609A	
26H5-589A	26H5-609A	26H5-619A	
26H5-599A	26H5-619A	26H5-629A	
26H5-609A	26H5-629A	26H5-639A	
26H5-619A	26H5-639A	26H5-649B	
26H5-629A	26H5-649B	26H5-659A	
26H5-639A	26H5-659A	26H5-669A	
26H5-649B	26H5-669A	26H5-679A	
26H5-659A	26H5-679A	26H5-689A	
26H5-669A	26H5-689A	26H5-699A	
26H5-679A	26H5-699A	26H5-709A	
26H5-689A	26H5-709A	26H5-719A	
26H5-699A	26H5-719A	26H5-729A	
26H5-709A	26H5-729A	26H5-739A	
26H5-719A	26H5-739A	26H5-749A	
26H5-729A	26H5-749A	26H5-759A	
26H5-739A	26H5-759A	26H5-769A	
26H5-749A	26H5-769A	26H5-779A	
26H5-759A	26H5-779A	26H5-789A	
26H5-769A	26H5-789A	26H5-799A	
26H5-779A	26H5-799A	26H5-809A	
26H5-789A	26H5-809A	26H5-819A	
26H5-799A	26H5-819A	26H5-829A	
26H5-809A	26H5-829A	26H5-839A	
26H5-819A	26H5-839A	26H5-849A	
26H5-829A	26H5-849A	26H5-859A	
26H5-839A	26H5-859A	26H5-869A	
26H5-849A	26H5-869A	26H5-879A	
26H5-859A	26H5-879A	26H5-889A	
26H5-869A	26H5-889A	26H5-899A	
26H5-879A	26H5-899A	26H5-909A	
26H5-889A	26H5-909A	26H5-919A	
26H5-899A	26H5-919A	26H5-929A	
26H5-909A	26H5-929A	26H5-939A	
26H5-919A	26H5-939A	26H5-949A	
26H5-929A	26H5-949A	26H5-959A	
26H5-939A	26H5-959A	26H5-969A	
26H5-949A	26H5-969A	26H5-979A	
26H5-959A	26H5-979A	26H5-989A	
26H5-969A	26H5-989A	26H5-999A	
26H5-979A	26H5-999A	26H5-1009A	

UNITS WITHOUT CRUSHER WEIGH 301 LB. NET.
WITH CRUSHER, UNITS WEIGH 341 LB. NET.

DR. F.R.A.	TR. R.O.	DATE 6-8-62	AUTOMATIC ICE MAKER - WATER COOLED	DWG. NO.	26H5-423	REV.	A
CHK. D.E.M.	APPD. E.L.V.	SUPERSEDES		ISSUE OF 11-19-58			

1. CHECK SHIPMENT

The unit is shipped in three cartons. One contains the machine compartment, one the storage bin and one the siphon interchanger assembly.

**TABLE 1 - PARTS LIST
MACHINE SECTION CRATE**

Model	Quantity	Description
26H3	1	Machine Section
	1	Outside Standpipe
	1	Water Strainer
	1	Crusher Guard*
	1	Inside Standpipe & Rubber Grommet
26H5	1	Machine Section
	1	Outside Standpipe
	1	Water Strainer
	1	Crusher Guard*
	1	Inside Standpipe & Rubber Grommet

* On units equipped with crusher only.

STORAGE BIN CRATE

Size, Lb.	Quantity	Description
100, 160, 240,	1	Storage Bin
500	4	Leveling Screws

HEAT INTERCHANGER PACKAGE

Quantity	Description
1	Interchanger
1	Rubber Hose
2	Hose Clamps

STORAGE BIN PARTITION

Quantity	Description
1	Partition Machine Screws

2. SELECT PROPER LOCATION

Select a location for the unit before delivery. The following should be considered:

1. Convenience - Select a clean dry place as close as possible to the point of ice consumption. Consult the user before deciding.
2. Room Temperatures
Minimum 50 F - Room temperatures below this may cause erratic control operation.
Maximum 100 F - Room temperatures above this overload the compressor and reduce unit capacity.
3. Floor Strength - See Table 2.

**TABLE 2 - OPERATING WEIGHT AND
DIMENSIONS**

Model No.	Total Weight (Bin Full of Ice)	Bin Cap.	Floor Area (In.)
26H3	389	100	25 x 24
26H5	565	160	25 x 24
26H5	676	240	25 x 34
26H5	940	500	32 x 50

NOTE: Add 40 lb for Crusher.

4. Clearance:

Top	10" Minimum
Rear and Sides	6" Minimum
Front	24" Minimum

5. Water Supply - See Section 12.
6. Drain Connections - See Section 12.
7. Electrical Connections - See Section 13.

3. MOVE UNIT TO LOCATION

Move the unit to the proper location before uncrating. Crated dimensions are shown in Table 3.

TABLE 3 - CRATED DIMENSIONS

	Height (in.)	Depth (in.)	Width (in.)	Weight (lb.)
26H5 Machine Section	43-1/2	23-1/2	28-1/2	307
26H3 Machine Section	43-1/2	23-1/2	28-1/2	236
100 lb. Bin	31-1/2	27	26	95
160 Lb. Bin	39-1/2	26-1/2	25	112
240 Lb. Bin	39-1/2	26-1/2	35	142
500 Lb. Bin	45-1/2	34-7/8	49-1/2	225
Heat Interchanger	22-1/2	17	5	18

4. UNCRATE THE BIN

Uncrate the bin first since it serves as the base for the unit.

5. INSTALL LEVELING SCREWS

Support the bin with the four leveling screws supplied with the bin. See Fig. 1. The top of the bin can be used for leveling.

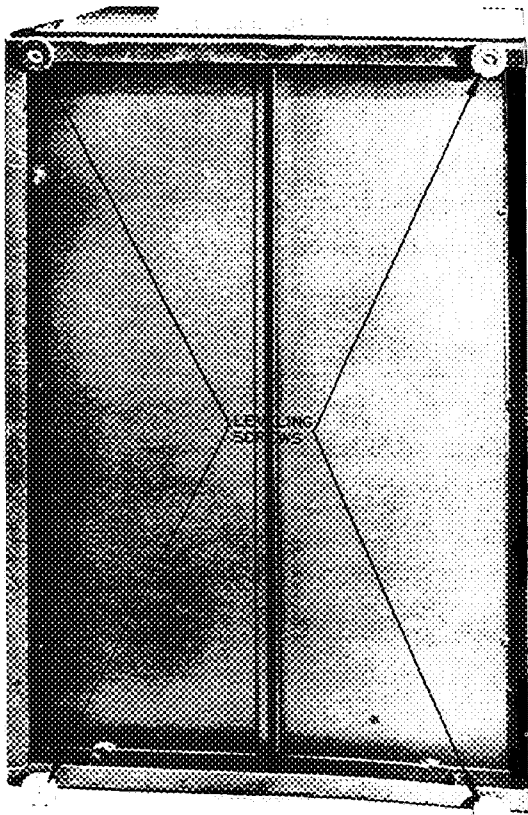

FIG. 1 - LEVELING SCREWS INSTALLED

6. UNPACK AND MOUNT THE HEAT INTERCHANGER

Remove the interchanger and parts from the carton. Mount the heat interchanger on the back of the bin with the 6 sheet metal screws in the paper envelope. The position of the interchanger on the back of the bin is shown in Fig. 2.

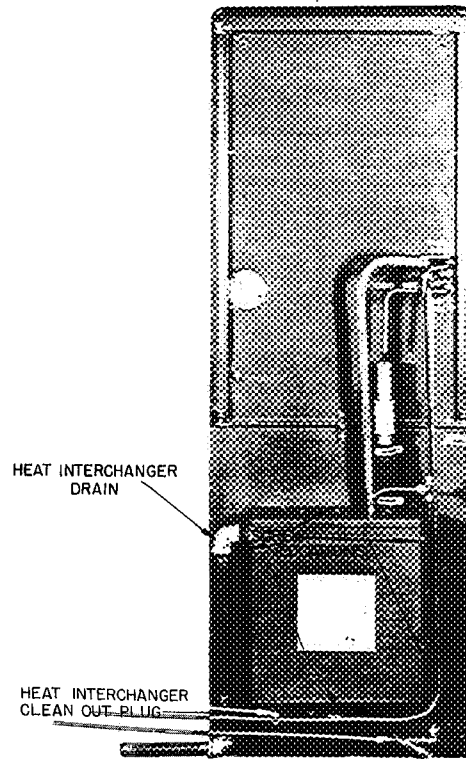

FIG. 2 - POSITION OF HEAT INTERCHANGER ON THE BIN

7. MOVE THE BIN TO APPROXIMATE LOCATION

Move the bin as close as possible to the final location before placing the machine section on top of it.

8. UNCRATE THE MACHINE SECTION

Uncrate the machine section as shown in Figs. 3 and 4.

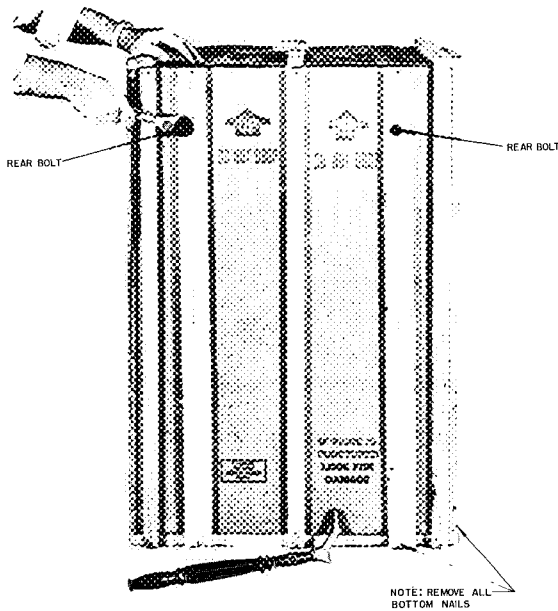

FIG. 3 - UNCRATING - REAR BOLTS

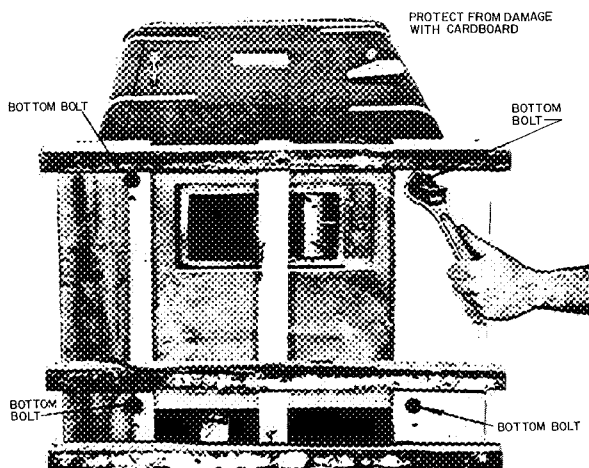

FIG. 4 - UNCRATING - BOTTOM BOLTS

9. REMOVE THE FRONT TOP, AND SIDE PANELS

Remove the front, top, and side panels in that order before moving the machine section.



FIG. 5 - REMOVING SCREWS HOLDING TOP AND SIDE PANELS

10. PLACE MACHINE SECTION ON TOP OF BIN AND BOLT IN POSITION

Remove the short front panel. Using the two cap-screws in the cloth bag shipped with the bin, bolt the machine section in place as shown in Fig. 6.

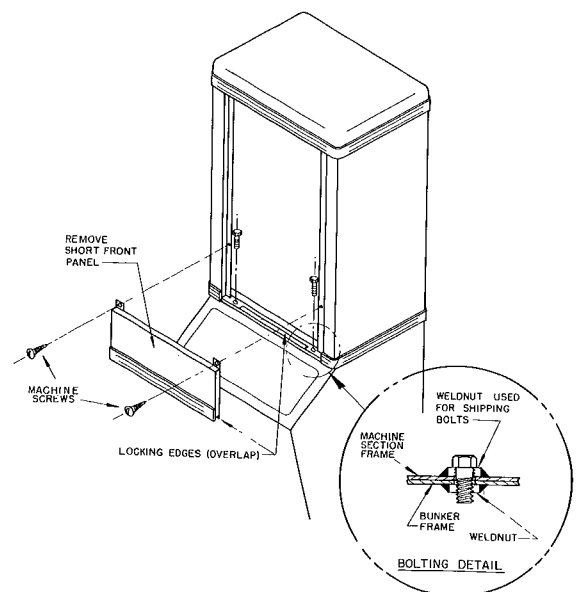

FIG. 6 - BOLTING MACHINE SECTION TO BIN

11. BOLT TIE BAR AT REAR OF UNIT

Lock the two sections together with the tie bar shipped on the back of the machine section. See Fig. 7.

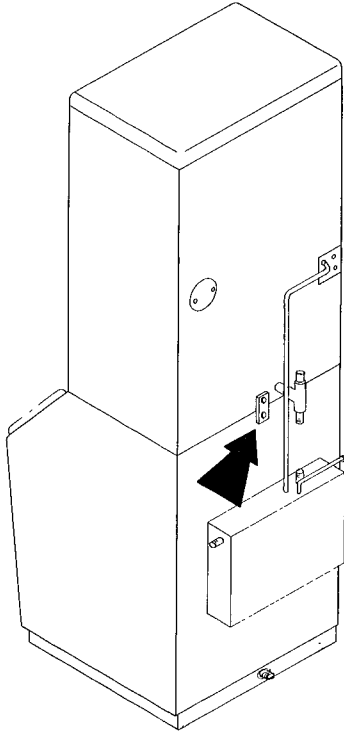

FIG. 7 - BOLTING TIE BAR AT REAR OF UNIT

12. INSTALL WATER SUPPLY AND DRAINS

Fig. 8 shows the piping connections and parts supplied by the factory. Any approved source of drinking water can be used provided a 30-60 lb. water pressure can be maintained. If the pressure exceeds 60 lbs. a pressure reducing valve must be used.

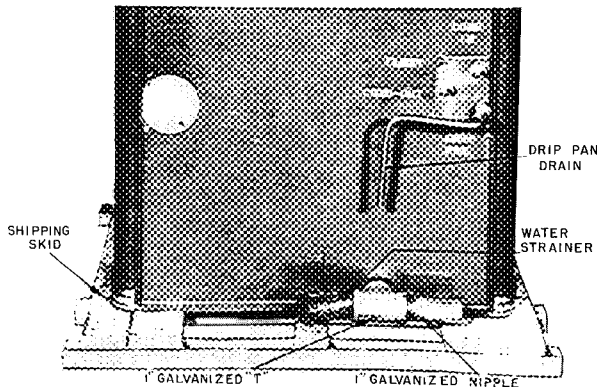

FIG. 8 - PARTS SHIPPED ON BACK OF MACHINE SECTION

Refer to Fig. 9 for recommended piping details.

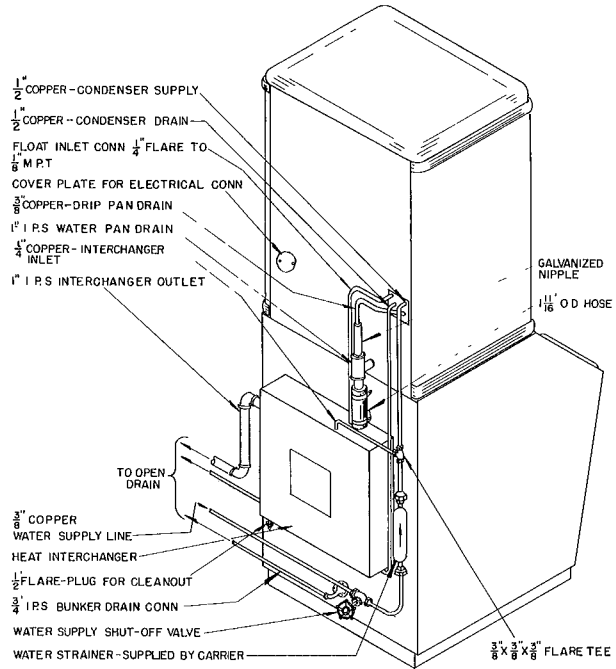

FIG. 9 - PIPING DIAGRAM

The drain lines should be piped separately to an open drain. The bin drain must be pitched downward for gravity flow. See Fig. 10.

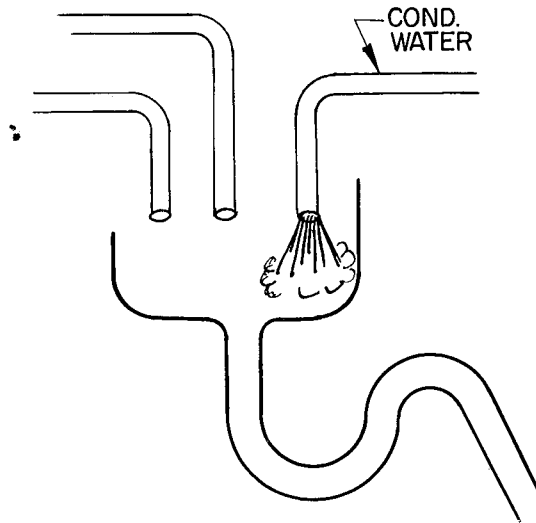

FIG. 10 - OPEN DRAIN

13. MAKE ELECTRICAL CONNECTIONS

Obtain a voltmeter or the special portable line voltage tester recommended in the Carrier Product Information Book. For satisfactory results, the voltage when the unit is running must always remain within 10 percent of the rated nameplate voltage. Check the current supply at the customer's premises and resolve any wiring problems before proceeding with the installation. See Table 4 for necessary electrical data.

208V APPLICATION "BUCK AND BOOST" TRANSFORMER

For application on 208 volt circuits, a transformer is recommended to boost the voltage from 208 volts to 230 volts. The information in Table 5 should be helpful in selecting the transformers. It is selected on the basis of making a 10% voltage boost from 205 volts to 225 volts.

TABLE 4

MODEL	VOLTAGE	FULL LOAD CURRENT	FUSETRON SIZE	WIRE SIZE (AWG) TYPE R,T			
				LENGTH OF RUN			
				25'	50'	100'	200'
26H3	115	10.8	15	14	12	10	6
26H5	115	13.4	17 1/2	12	12	8	6
26H5	230	6.7	9	14	14	14	12

TABLE 5 - 208V APPLICATION

Carrier Part No.	General Electric Part No.	Total Amps Allowable	
HT04AH026	9T51Y6171	12.5 amps.	Two units without crushers or one unit with crusher plus one without crusher. Will <i>NOT</i> handle two units with crushers.
HT04AH035	9T91Y6172	25 amps.	Four units without crushers or two units with crushers plus two units without crushers. Will <i>NOT</i> handle four units with crusher.
Not stocked at Carrier		37.5 amps.	Six units without crushers or three units with crushers plus three units without crushers

The wiring connections for this transformer for a 10% voltage boost are as follows:

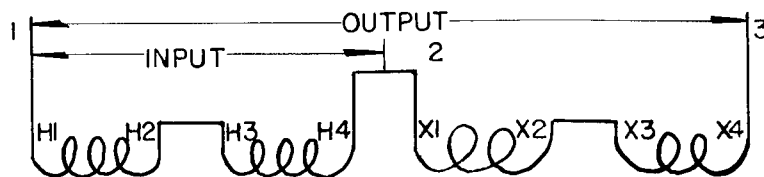

FIG. 11 - "BUCK AND BOOST" TRANSFORMER WIRING

14. INSTALL BIN THERMOSTAT BULB

Remove the tape holding the bin thermostat capillary and bulb in a coiled position inside the right side of the machine section. Uncoil 4 or 5 loops of the capillary and insert the bulb through the hole in the right rear corner of the machine section into the bin. Run the capillary along the top of the bin and down the back of the thermostat bulb bracket. See Figs. 12 and 13.

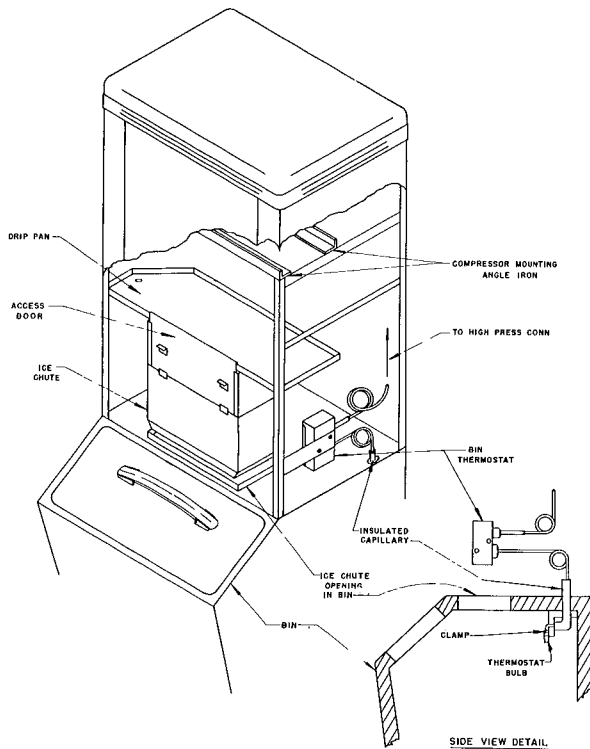

FIG. 12 - BIN THERMOSTAT CAPILLARY AND BULB ARRANGEMENT

26H5-500, 240 AND 160 LB. BINS

Attach the clamp to the bottom hole in the bracket; insert the thermostat bulb in the clamp so it extends 1/2" below the bottom of the bracket. Tighten the clamp.

26H3-100 LB. BINS

With the clamp attached to the bracket at the top hole in the arm of the bracket, insert the thermostat bulb in the clamp so the clamp is approximately in the middle of the bulb and tighten the clamp.

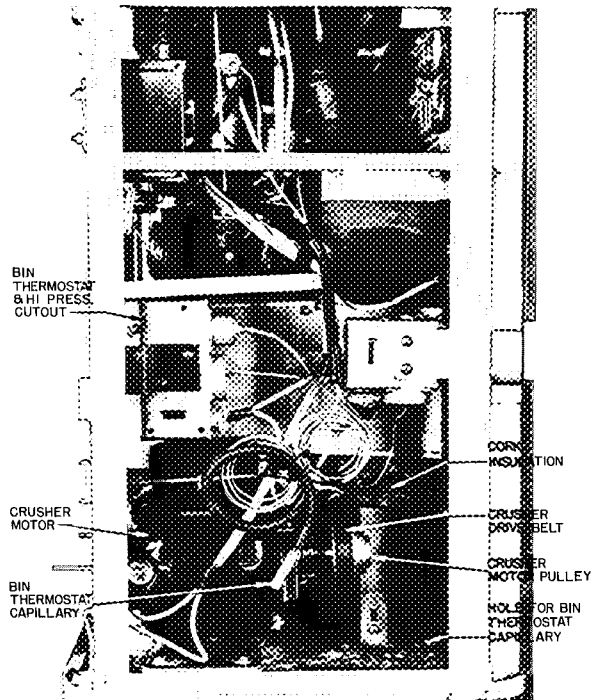

FIG. 13 - RIGHT SIDE OF 26H3 SECTION - PANELS REMOVED

Instructions for mounting the thermostat capillary and bulb on a partition are included in the partition package.

CAUTION: Insulate the capillary where it goes through the hole in the machine section and the bin with tape or rubber tubing.

15. INSTALL CRUSHER GUARD

Remove crusher guard assembly from ice chute on crusher models and install per instructions in paragraph 19 on page 39.

16. INSTALL SIPHON STANDPIPE AND ADJUST FLOAT

Remove the ice deflector to gain access to the water pan. Fig. 14.

Place standpipe assembly and rubber grommet in water pan drain. (See Fig. 14). On 26H3 unit, remove knockout in stainless steel jacket. (Do *not* remove on 26H5 unit.)

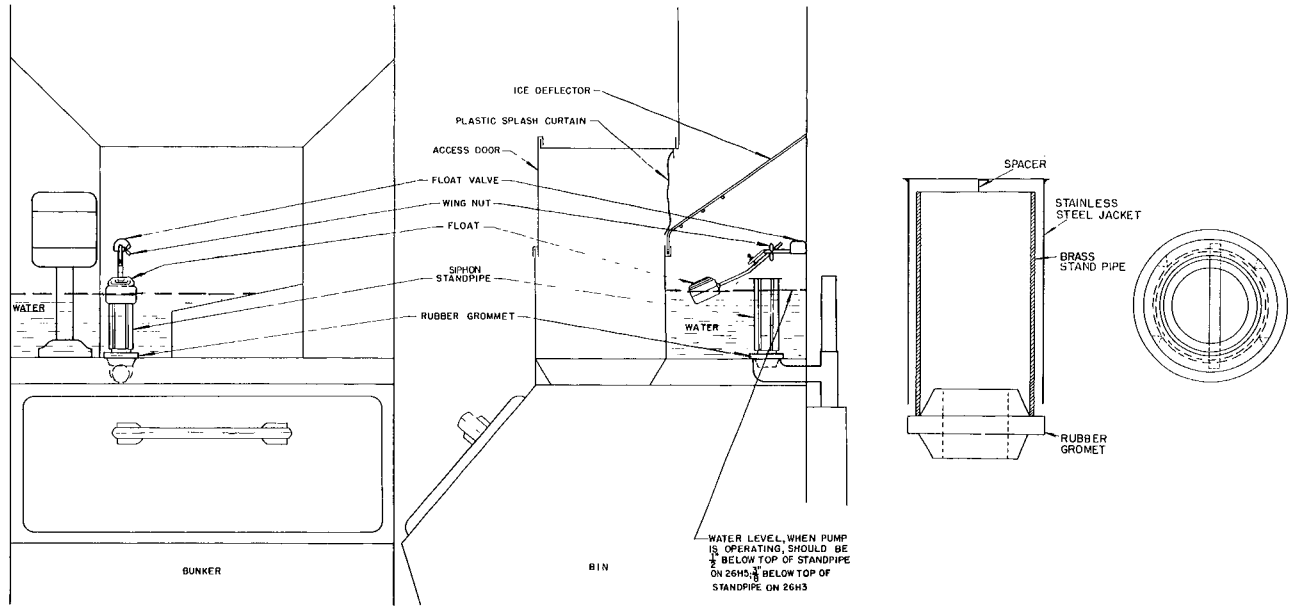

FIG. 14 - CORRECT WATER LEVEL

Turn on the water and set the float valve to maintain a water level $\frac{3}{8}$ " below the top of the siphon standpipe for the 26H3 and $\frac{1}{2}$ " below for the 26H5. See Fig. 14.

The water level should be set with the pump off, and checked again with the pump running, after the water level has settled. To check the Siphon action let the unit run on "Pump" until the float shuts off the water to the pan. Turn the selector switch to "Off". The water in the header and the water pipes will drop down and raise the water pan level until the Siphon action begins and the water pan is siphoned out.

If the water pan fails to siphon out, the water level has been set too low. If the water siphons or overflows the inner standpipe when the pump is running, the water level has been set too high.

After the float is set, tighten the wing nut on the float arm and the setscrew to the flat on the float arm. See Fig. 15.

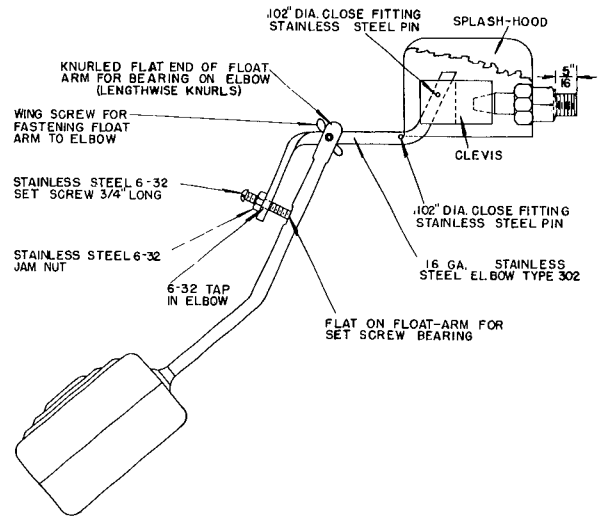

FIG. 15 - SKETCH OF WATER VALVE AND FLOAT ASSEMBLY

17. REPLACE THE ICE DEFLECTOR

The bottom of the deflector sets in two clips fastened to the inside front wall of the water pan. The back of the ice deflector rests against the front of the evaporator shroud. See Fig. 14.

18. LOOSEN COMPRESSOR HOLD-DOWN BOLTS

26H5

Loosen the four compressor hold-down bolts. See Fig. 16. Check to see that the compressor is floating freely on its mounting springs.

When the machine is to be moved, retighten the hold down bolts to prevent damage.

26H3

The 26H3 is spring mounted internally. Do not loosen compressor hold-down bolts.

19. START THE UNIT

Shutoff valves are backseated and the unit is ready for operation when shipped.

Turn the selector switch located under the hinged nameplate to the "ON" position and check the operation. See Fig. 17.

If the unit fails to start, push the reset button on the Safety Overflow Switch.

NOTE: The 26H5 unit may cycle several times on the high pressure cutout during initial start-up or after a prolonged shut-down. While such cycling is perfectly normal, it may

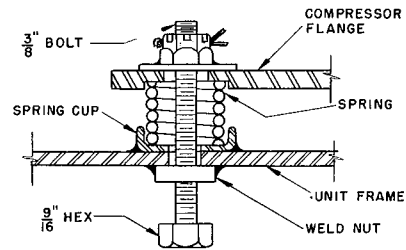

SHIPPING POSITION

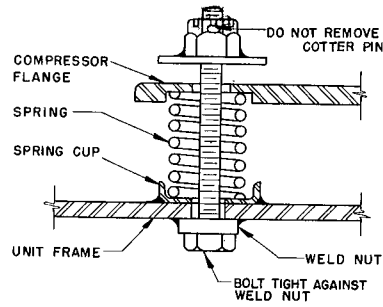

OPERATING POSITION

FIG. 16 - COMPRESSOR HOLD-DOWN BOLTS

be reduced by shutting off the unit for about a half a minute then starting again.

The 26H3 may cycle on overload several times upon attempting to start after a prolonged shutdown.

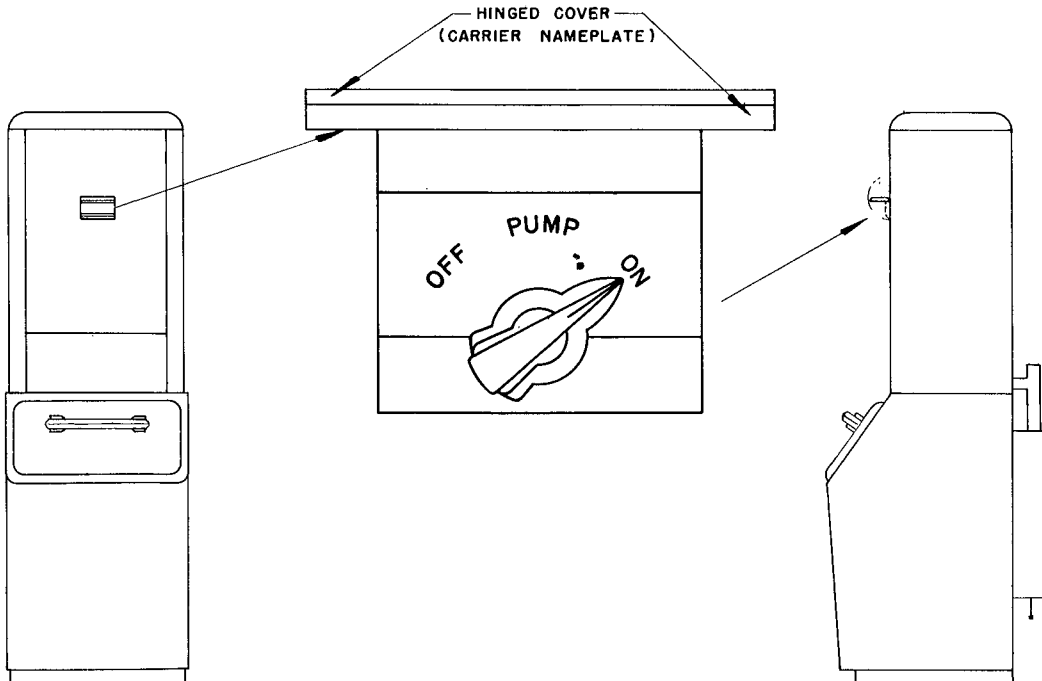

FIG. 17 - SELECTOR SWITCH

20. CHECK OPERATION

The operation should be as follows:

- (a) Freezing for 30 or 40 minutes - compressor operating, pump operating and hot gas solenoid closed. A longer freezing period may occur where the water supply temperature is high.
- (b) Defrosting for approximately 6 minutes - compressor operating, hot gas solenoid open and water pump off.
- (c) Overrun - Time, which is the time between the falling of the last cube and the start of the next freezing cycle, should be about 1/2 a minute to 1-1/2 minutes. To increase overrun time, raise the setting of the righthand element (cut in) of the Main Control Thermostat.
- (d) The hole in the average ice cube should be about 3/16" diameter. Run two or three batches, since the first harvest will produce cubes with larger than average holes.

21. FINAL CHECK LIST

- 1. Is the unit level?
- 2. Have all electrical and piping connections been made?
- 3. Has the overrun time (par 20C) been set?
- 4. Have all the controls been checked?
- 5. Has the voltage been load tested and checked against nameplate voltage?
- 6. Have the compressor hold-down bolts been loosened so that the compressor rides freely on its mounting springs?
- 7. Has the float been set so water will siphon out at the end of each freezing cycle?
- 8. Operate the unit for at least two or three cycles. Is it operating properly?
- 9. Is the unit quiet?
- 10. Is the unit clean?
- 11. Have the installation and warranty cards been filled out?
- 12. Has the owner been given the Operating Instruction booklet and has he been instructed on how to operate the machine?

Carrier



1. HOW THE AUTOMATIC ICE MAKER WORKS

The Ice Cube Maker is fully automatic and operates in two alternate cycles - first the freezing cycle, then the harvesting cycle. The compressor operates continuously during both cycles

FREEZING CYCLE (SEE FIG. 1)

During the freezing cycle water is pumped from the water pan (13) to a water header (16) at the top of the unit. From the water header it flows over individual spreader plates, down the four inside surfaces of each of the square, stainless steel freezing columns (18). Here water is frozen into individual cubes. This is accomplished by unique evaporator design. Copper sleeves are bonded to the outside of each stainless steel column at eight points spaced along its vertical dimension. Sections of the evaporator coils are in turn soldered to these copper bands. Because of the high rate of heat transfer through the copper and the low conductivity of the stainless steel, individual cubes start to form inside the columns opposite each copper band and grow from this point. The hole in the center is due to continuous water flow - necessary to form clear cubes.

DEFROST CYCLE (SEE FIG. 2)

When the passage through any one of the columns becomes restricted because of ice formation, water backs into the overflow trough, (19), and drops into

the thermostat well, (21). Here the cold water activates the cut-out side of the Ranco two-bulb control, (35A). This starts the harvest cycle by stopping the water pump (14), and opening the hot gas solenoid valve, (33). The solenoid valve allows hot gas to pass directly from the condenser, (2), to the evaporator coil, (6). The cubes are melted loose and allowed to drop through the ice chute into the storage compartment, or bin, (37). If the cubes fail to drop, the water will continue to build up in the overflow trough and will flow into the safety overflow well (23). This actuates a safety switch (24) and shuts the machine off.

The hot gas passing from the evaporator coil through the suction line, warms the capillary bulb (35B) attached to the vertical portion of the suction line leading from the first accumulator. The warming of this bulb activates the cut-in side of the Ranco two-bulb control, which starts the machine on the freezing cycle. As soon as the Ranco control moves the machine into the freezing cycle, the water pump is automatically started and the solenoid valve closes.

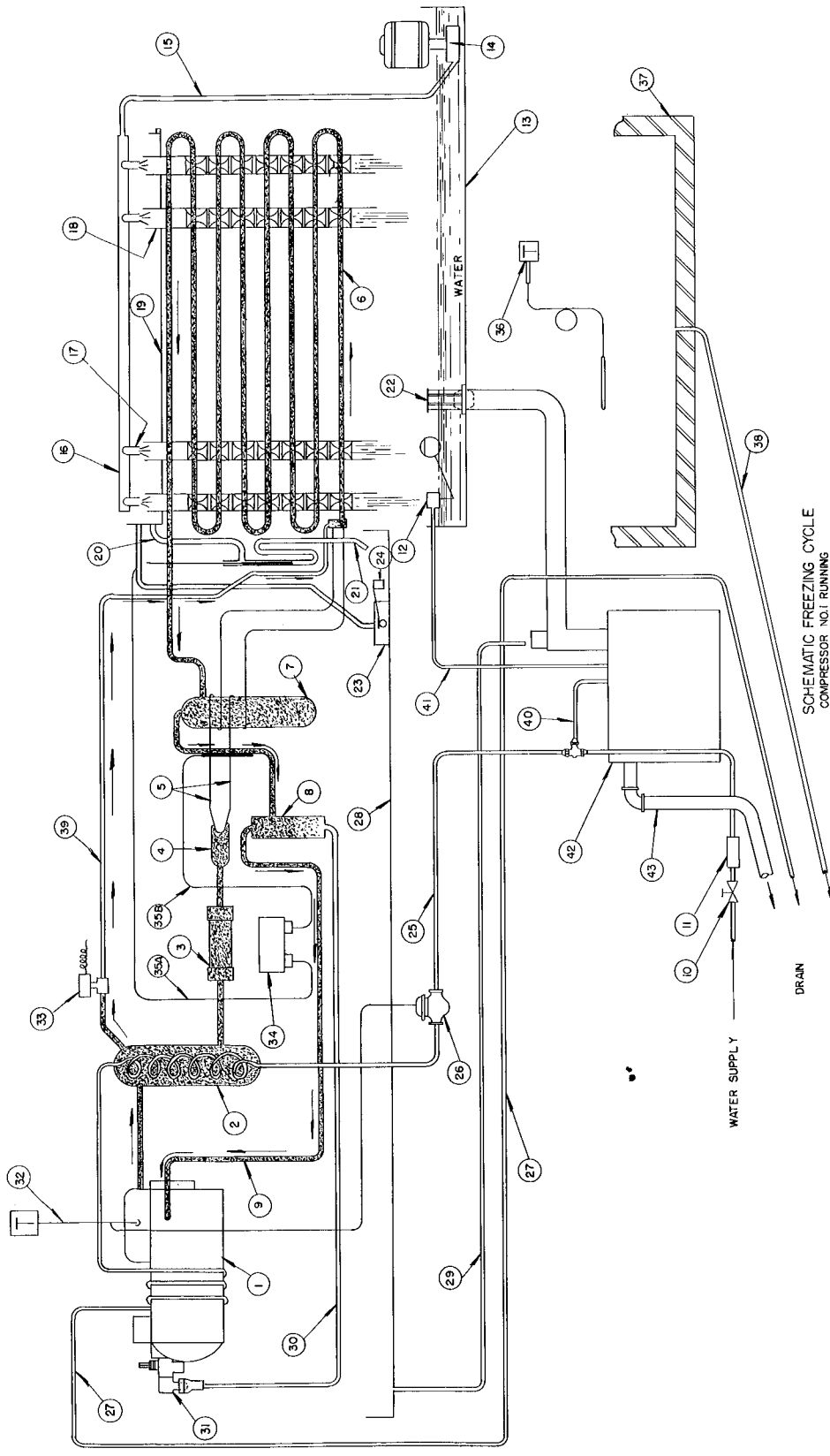

SCHEMATIC FREEZING CYCLE
 COMPRESSOR NO.1 RUNNING
 WATER PUMP NO.14 RUNNING
 HOT GAS SOLENOID VALVE NO.33 CLOSED
 ICE CUBES BEING FROZEN IN COLUMNS NO.18

- 1- COMPRESSOR
- 2- CONDENSER
- 3- STRAINER & DRYER
- 4- WATER PUMP
- 5- THERMOSTAT CUT-IN CAPILLARIES
- 6- EVAPORATOR COILS
- 7- 1ST ACCUMULATOR
- 8- 2ND ACCUMULATOR
- 9- SHUT-OFF VALVE (WATER SUPPLY)
- 10- WATER STRAINER
- 11- WATER STRAINER
- 12- FLOAT VALVE
- 13- OVERFLOW TROUGH
- 14- WATER PUMP
- 15- WATER LINE (MAIN) TO WATER HEADER
- 16- WATER HEADER
- 17- WATER NOZZLES
- 18- FREEZING COLUMNS
- 19- OVERFLOW TROUGH
- 20- DRAIN LINE FROM OVERFLOW TROUGH
- 21- THERMOSTAT CUT-OUT WELL
- 22- SIPHON STANDPIPE (WATER PAN DRAIN)
- 23- SAFETY OVERFLOW WELL
- 24- SAFETY OVERFLOW SWITCH
- 25- WATER SUPPLY TO CONDENSER
- 26- CONDENSER WATER DRAIN
- 27- CONDENSER WATER DRAIN
- 28- DRIP PAN FOR MACHINE SECTION
- 29- OIL RETURN LINE
- 30- OIL RETURN LINE
- 31- SERVICE SHUT-OFF VALVE
- 32- HIGH PRESSURE CUT VALVE
- 33- HOT GAS SOLENOID VALVE
- 34- MAIN CONTROL THERMOSTAT
- 35A- MAIN CONTROL CUT-OUT CAPILLARY
- 35B- MAIN CONTROL CUT-IN CAPILLARY
- 36- BIN THERMOSTAT
- 37- BIN
- 38- BIN DRAIN
- 39- HOT GAS LINE
- 40- WATER SUPPLY TO HEAT INTERCHANGER
- 41- WATER SUPPLY TO HEAT INTERCHANGER
- 42- HEAT INTERCHANGER
- 43- HEAT INTERCHANGER DRAIN

FIG. 1 - SCHEMATIC FREEZING CYCLE

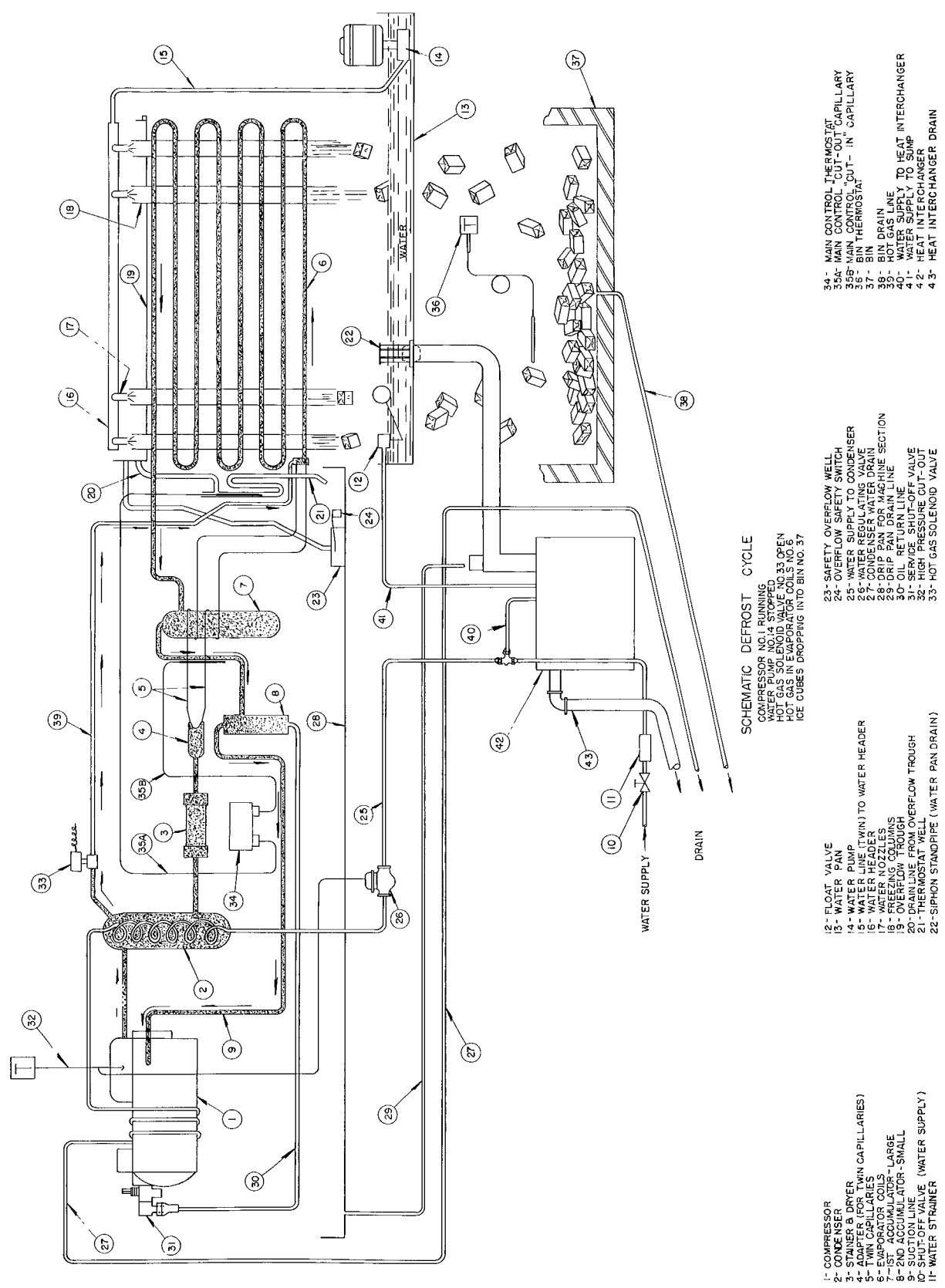

SCHEMATIC DEFROST CYCLE

COMPRESSOR NO. 1 RUNNING
 WATER SUPPLY STOPPED
 HOT GAS IN VAPORATOR COILS NO. 6
 ICE CUBES DROPPING INTO BIN NO. 37

- | | | |
|--|-------------------------------|---------------------------------------|
| 1- COMPRESSOR | 23- SAFETY OVERFLOW WELL | 34- MAIN CONTROL THERMOSTAT |
| 2- CONDENSER | 24- OVERFLOW SAFETY SWITCH | 35A- MAIN CONTROL "CUT-OUT" CAPILLARY |
| 3- STAINER & DRYER | 25- WATER SUPPLY TO CONDENSER | 35B- MAIN CONTROL "CUT-IN" CAPILLARY |
| 4- ADAPTER (FOR TWIN CAPILLARIES) | 26- WATER REGULATING VALVE | 36- BIN THERMOSTAT |
| 5- TWIN CAPILLARIES | 27- CONDENSER WATER DRAIN | 37- BIN |
| 6- WATER NOZZLES | 28- DRAIN PAN | 38- HOT GAS LINE |
| 7- ISOLATING VALVE | 29- DRAIN LINE | 39- HOT GAS LINE |
| 8- 2ND ACCUMULATOR - SMALL | 30- OIL RETURN LINE | 40- WATER SUPPLY TO PUMP |
| 9- SUCTION LINE (WATER SUPPLY) | 31- SERVICE SHUT-OFF VALVE | 41- HEAT INTERCHANGER |
| 10- SHUT-OFF VALVE (WATER SUPPLY) | 32- HIGH PRESSURE CUT-OUT | 42- HEAT INTERCHANGER DRAIN |
| 11- WATER STRAINER | 33- HOT GAS SOLENOID VALVE | |
| 12- FLOAT VALVE | | |
| 13- WATER PAN | | |
| 14- WATER PUMP | | |
| 15- WATER LINE (TWIN) TO WATER HEADER | | |
| 16- WATER HEADER | | |
| 17- WATER NOZZLES | | |
| 18- DRAIN PAN | | |
| 19- OVERFLOW TROUGH | | |
| 20- DRAIN LINE FROM OVERFLOW TROUGH | | |
| 21- THERMOSTAT WELL | | |
| 22- SIPHON STANDPIPE (WATER PAN DRAIN) | | |

FIG. 2 - SCHEMATIC DEFROST CYCLE

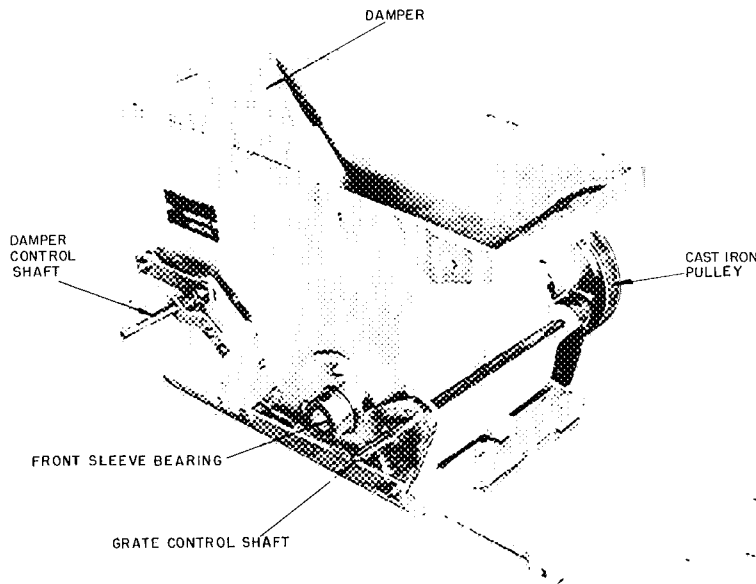

FIG. 3 - ICE CRUSHER ASSEMBLED - FRONT VIEW

CRUSHER OPERATION

The defrost and freezing cycles of an Ice Maker with a crusher are identical to those of units without a crusher. Normally the crusher is a factory mounted accessory, enclosed in the machine section. If desired, a crusher package may be purchased separately for installation. (See Fig. 3)

CAUTION: When cleaning units equipped with crushers or performing service operations, disconnect the power supply.

The two crusher control knobs are mounted on the lower front panel (Fig. 4). When the knob on the left is positioned on "Crushed", the cubes pass through the crusher and crushed ice falls into the bin. Fineness of the crushed ice is controlled by the knob on the right. When the knob on the left is positioned on "Cubes", the ice cubes bypass the crusher and fall into the bin.

The knob marked "Crushed - Cubes" controls a switch to the crusher motor and the position of a damper to direct the cubes. The motor is cut out of the control circuit when the switch is turned to "Cubes".

When ice builds up in the bin and touches the thermostat bulb, the unit will stop. If the crusher knob

is in the "Crushed" position and the bin thermostat stops the unit during the harvest cycle, the crusher motor will continue to operate until the main control switches to the freezing position or the selector switch is turned to "Pump" or "Off". This prevents accumulation of cubes at the crusher entrance.

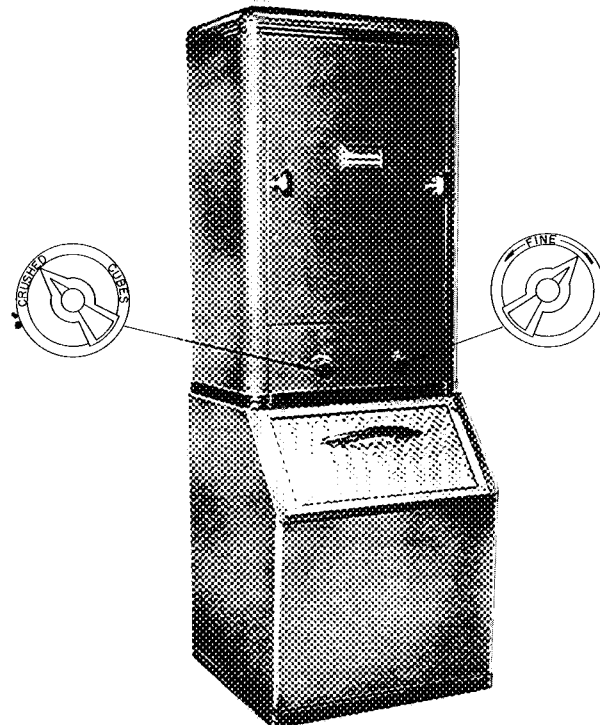

FIG. 4 - ICE CRUSHER CONTROLS

REMOVING THE PANELS

To remove the top front panel turn both handles so they are horizontal and lift it out. To remove the top panel remove the screws shown in Fig. 5. Tilt



FIG. 5 - REMOVING SCREWS HOLDING TOP AND SIDE PANELS

the panel up and back to disengage it from the back panel. The side panels are held in place at the front by two screws and the bottom front panel. The side panels engage with the flanged edge of the back panel. Do not remove the back panel except when absolutely necessary. It is held in place by six screws threaded into the frame.

Cleaning and inspecting can be done by removing the front access door, splash curtain, and ice deflector screen. The plastic curtain is riveted to a cross arm held in place by two screws (Fig. 6).

After inspection and cleaning, be sure to reposition the plastic curtain properly to prevent water from splashing into the bin. (Fig. 7).

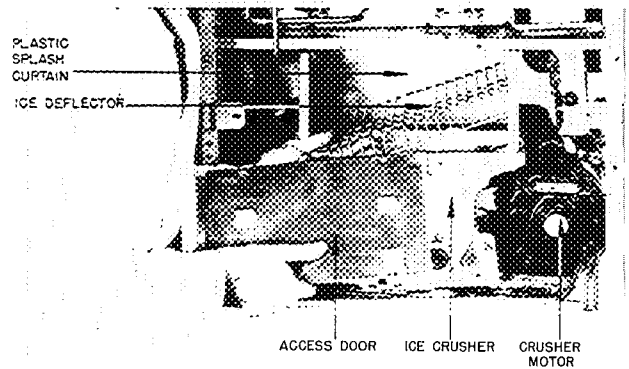

FIG. 6 - REMOVING ACCESS DOOR AND ICE DEFLECTOR

2. REFRIGERANT CIRCUIT

1. SHUTOFF VALVES

Fig. 8 is a cross sectional view of a shutoff valve in mid-position. When the unit is shipped all valves are backseated and should be left so during normal operation. A brass cap and gasket cover the valve stem to prevent leaks. The gauge ports are plugged with two 1/8" MPT plugs.

26H3

There are two shutoff valves in the circuit - a suction valve and a discharge valve. (See Fig. 9).

26H5

There are three shutoff valves in the circuit - a suction valve, discharge valve, and oil return valve. (See Fig. 10).

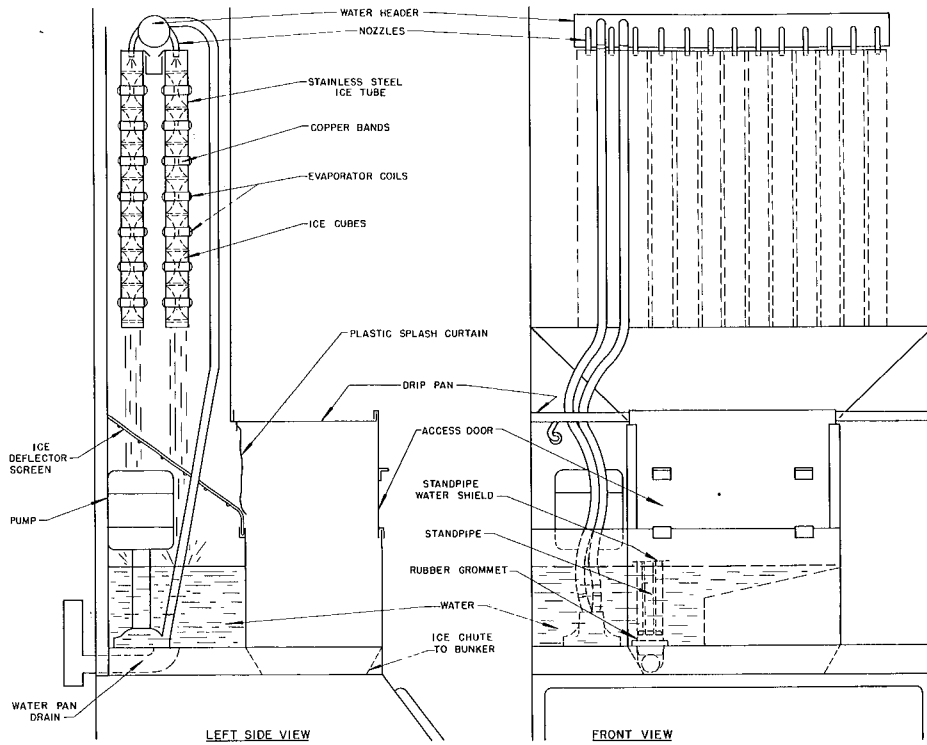

FIG. 7 - FREEZING COLUMNS, ICE DEFLECTOR, SPLASH CURTAIN, SIPHON STANDPIPE, ACCESS DOOR AND WATER PAN ARRANGEMENT

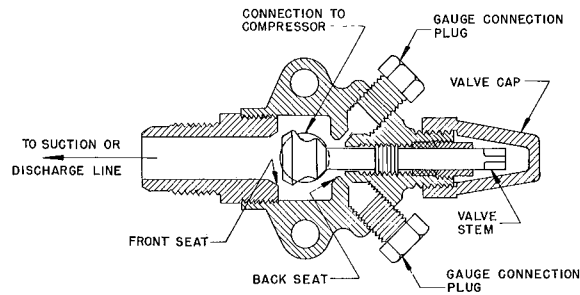

FIG. 8 - SHUTOFF VALVE

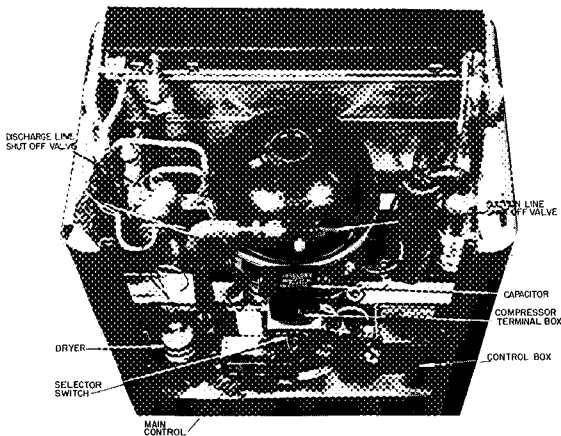

FIG. 9 - TOP VIEW OF 26H3 MACHINE SECTION

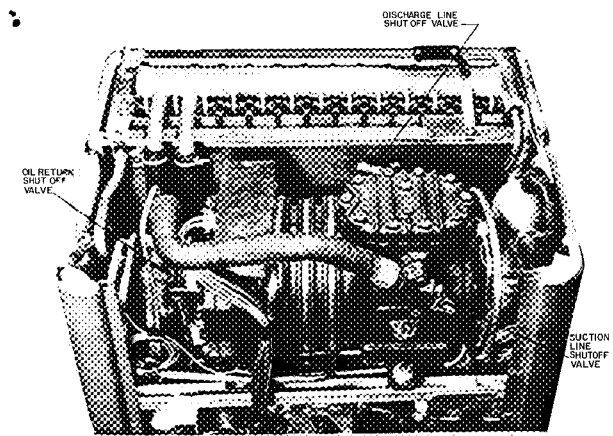

FIG. 10 - TOP VIEW OF 26H5 MACHINE SECTION

2. INSTALLING GAUGES

- a. Backseat suction and discharge shutoff valves.
- b. Remove gauge plugs and install 1/8" MPT x 1/4" flare half union coupling.
- c. Attach 1/4" OD copper gauge line, flared at both ends, to the couplings.
- d. Attach suction and discharge gauges to these lines, leaving connection slightly loose.
- e. Crack the valve off back seat, allow a small amount of refrigerant to escape, and tighten the flare nut.

To read line pressures, turn the shutoff valves slightly from the backseat position. If the gauge needle vibrates, backseat the valve until there is no vibration but the gauge still reads line pressure.

NOTE: To conserve refrigerant, use short lengths of small bore tubing when installing gauges. This unit is sensitive to charge and repeated installation and removal of gauges with necessary purging of air will result in an undercharge of refrigerant.

3. PUMP DOWN OF COMPRESSOR

If the refrigeration system must be opened at the compressor, first "Pump Down". Proceed as follows:

1. Install a pressure gauge to the suction shutoff valve.
2. Front seat the suction shutoff valve.
3. Front seat the oil return line shutoff valve (on 26H5).
4. Operate the compressor intermittently until the suction pressure gauge indicates 0 to 2 PSIG pressure is being maintained in the crankcase.
5. With the compressor stopped, front seat the discharge shutoff valve.

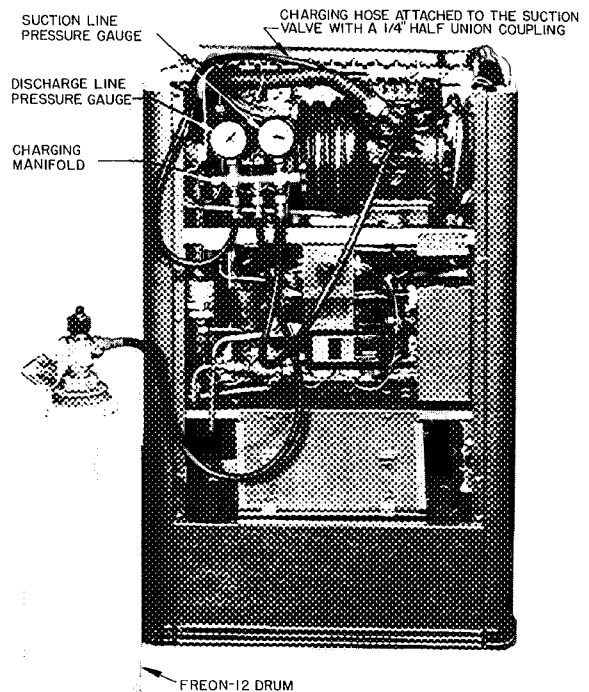

FIG. 11 - CHARGING MANIFOLD ATTACHED FOR CHARGING UNIT

6. Loosen the discharge shutoff valve gauge plug slightly and bleed off any remaining pressure. The compressor can then be opened or removed.
7. After repairing the compressor, evacuate and purge it to remove residual air. Remove the pipe plug from the gauge connection of the discharge shutoff valve. Operate the compressor for about 10 minutes. Place your thumb over the discharge valve gauge connection, at the same time stopping the compressor. Crack open the SUCTION shutoff valve, momentarily, allowing a small amount of gas to enter the compressor. Front seat the suction shutoff valve immediately. A slight gas pressure should not be felt against your thumb. Replace the pipe plug. The suction, discharge and oil return line shutoff valves can now be backseated and the machine is ready for operation.

4. CHARGING WITH REFRIGERANT

TABLE 1 - REFRIGERANT CHARGE (R12)

MODEL	IDENTIFICATION	CHARGE
26H5	No changes	3 lb. 8 oz.
26H3	9" condenser and 9" accum.	1 lb. 11 oz.
26H3	Serial No. 331784 Change to 18" cond.- 9" accumulator	2 lb. 3 oz.
26H3	Serial No. 411152 change to 15" cond.- 9" accumulator	2 lb. 3 oz.
26H3	Serial No. 510446 change to 15" cond.- 10 1/2" accumulator	2 lb. 9 oz.

If the unit is undercharged, back seat the suction shutoff valve. Remove a gauge port plug from the valve; connect a charging line from a drum of refrigerant 12. Tighten this line at the drum, but make a loose connection at the suction shutoff valve. Crack the valve on the drum so that refrigerant vapor will force air from the charging line out the loose connection. After purging the air from the charging line, tighten the connection at the suction shut-off valve. Open the suction valve to a point midway between the back-seated and front-seated positions. With the suction shutoff valve in this position, it is possible to read the system pressure during the charging period. The refrigerant 12 drum should be in an upright position to admit vapor only.

If the unit is overcharged, turn the unit off. Back seat the discharge shutoff valve. Attach a charging line to one of the gauge ports in the valve and attach a charging manifold to the other end of the charging line. Turn the shutoff valve to the middle position; start the unit. Bleed refrigerant from the charging manifold in 5-second intervals until the charge is correct. Turn the unit off. Back seat the shutoff valve and remove the charging line. Replace the gauge port plug and start the unit.

WEIGHING IN CHARGE

The most accurate method of charging a refrigerant system is weighing in the charge. Proceed as follows:

1. Bleed any charge remaining in the system, then start the compressor and pump out the system through the discharge valve.
2. With the compressor still running, connect the drum of refrigerant to the suction valve.
3. Back seat the discharge valve and immediately turn off the compressor.
4. Weigh the drum of refrigerant (it is easier to weigh a charge if the weight of the drum can be checked during the charging process).
5. Open the suction valve and crack the valve on the drum of refrigerant. Start the compressor.
6. Continue to charge until the scale shows the proper amount of refrigerant has been fed into the system.
7. Close the valve on the drum and then the suction shutoff valve.
8. Disconnect the charging line.
9. Leak test the system.

FROST LINE METHOD OF CHARGING

By establishing a frost point on the suction line, it is possible to charge these units to within one ounce of their specified charge. By this frost point, it is also possible to determine whether or not a machine is only partially charged. Below are listed the recommended methods for charging the H3 and H5 ice makers, which require a partial or a full charge. Frostline should be at the point indicated when the machine has operated on the freezing cycle for 20 minutes.

CAUTION: If Freon is added in small amounts, the frost line will continue to move towards the small accumulator. If Freon is added too rapidly, the frost line will disappear. It is then necessary to wait until the frost reappears before adding or bleeding off refrigerant.

After making sure that the machine is leak free and in good running condition, proceed as follows with the pump running during the entire freezing cycle.

Method 1A - 26H3 Ice Maker No Charge in Unit

1. Start the unit with the pump running. Charge until the suction pressure is 15 PSIG.
2. Continue running the machine for 10 minutes without adding to the charge.
3. Add gas slowly until frost forms on the suction shutoff valve and the flare nut.
4. Bleed off slowly until frost just recedes from valve.

Method 1B - 26H3 Ice Maker Partial Charge in Unit

1. Start unit and let it run undisturbed for 20 minutes.

2. Charge slowly until the suction shutoff valve and flare nut frost
3. Bleed off gas until frost just recedes from valve.

Method 2A - 26H5 Ice Maker No Charge in Unit

1. Remove first clip immediately above small accumulator, and pull back two or three inches of the suction line insulation.
2. Start machine with pump on. Charge until suction pressure is 15 PSIG.
3. Discontinue charging and allow machine to run for 10 minutes. During this period, check to see if the suction pressure is holding at approximately 15 pounds.
4. Charge slowly until frost forms on the suction line between the small accumulator and the suction shutoff valve on the compressor.
5. Bleed off gas until frost line recedes back to the joint on the top of the second accumulator.
6. Allow machine to run through two complete cycles to check operating pressures.

Method 2B - 26H5 Ice Maker Partial Charge in Unit

1. Remove insulation from suction line 2 or 3" above second accumulator.
2. Start machine and allow it to run for 20 minutes undisturbed.
3. Charge slowly until frost forms on the suction line between the small accumulator and the suction shutoff valve.
4. Bleed off gas until frost line recedes back to the top of the second accumulator.
5. Allow machine to make two complete cycles to check its operating pressures.



5. OPERATING PRESSURES

Table 2 shows suction and head pressures during a normal freezing and defrost cycle.

6. COMPRESSOR

OIL CHARGE 26H3

The oil charge is 45 oz. Because of this large volume, the oil charge is not critical. The com-

pressor is a welded hermetic and there are no provisions for checking or adding oil in the field.

OIL CHARGE 26H5

The compressor is factory charged with two pints of Carrier PP45EB-302 oil which is a special low temperature refrigerant duty oil. Do not use ordinary motor oil. Before checking the oil level, operate the unit for at least 30 minutes to balance the oil distribution in the system.

TABLE 2 - 26H ICE MAKER OPERATING PRESSURES (PSIG)

TIME INTO CYCLE (MINUTES)		OPERATING PRESSURES											
		90° AIR - 90° WATER						90° AIR - 70° WATER					
		26H3 *		26H3 +		26H5		26H3 *		26H3 +		26H5	
		Head	Suction	Head	Suction	Head	Suction	Head	Suction	Head	Suction	Head	Suction
FREEZE	2	129	21	131	24	144	29	130	20	132	24	132	27
	4	131	20	134	23	150	29	131	19	132	22	134	23
	6	134	21	134	23	159	26	131	18	131	21	134	22
	8	134	20	132	22	149	24	132	17	131	20	130	20
	10	133	20	131	21	130	22	131	17	130	19	129	20
	15	130	18	130	19	130	19	131	17	130	17	127	18
	20	130	17	129	17	130	18	130	16	131	16	130	17
	25	132	16	129	16	128	17	132	16	131	15	131	16
	30	134	16	131	16	128	16	132	15	132	15	131	16
	35	130	15	131	15	128	15	130	15	133	14	131	15
40	129	15	130	15	128	15	129	14	132	14			
45	129	14	128	15									
DEFROST	2	115	52	79	34	55	30	124	55	77	30	65	33
	4	122	57	103	48	70	36	128	62	96	38	80	41
	6					100	58			106	44	100	57

* 26H3 From Serial No. 331784 to 510446

+ 26H3 From Serial No. 510446 to present.

To check the oil level:

- a. Install gauges and pump down the compressor.
- b. Remove one of the oil fill plugs on the side of the compressor.
- c. The oil level should be 1-1/4" as shown in Fig. 12. Oil can be added through the oil filler plugs. Reinstall the filler plug immediately to prevent absorption of moisture. It may damage the motor windings.

Caution: Avoid overcharging as excess oil may restrict the capillaries and reduce unit capacity. On those compressors with a sight glass, oil level should be between 1/2 and 2/3 above bottom of glass.

TESTING THE COMPRESSOR MOTOR

Series Test Light and Hermetic Test Cord

Fig. 13 shows a test cord that is useful as a 110/220 volt test light or as a cord for starting the compressor without using the unit controls. When used as a series test light, turn screw base outlet into the lamp socket, plug into a power source and use insulated leads indicated in Fig. 13 as probes to determine continuity. When used as a compressor starting cord, the fuse is used in the lamp socket.

To start compressor using test cord, disconnect all leads from compressor terminals. Clip common and running leads of cord to "C" and "R" terminals respectively. Plug cord into source of power, and

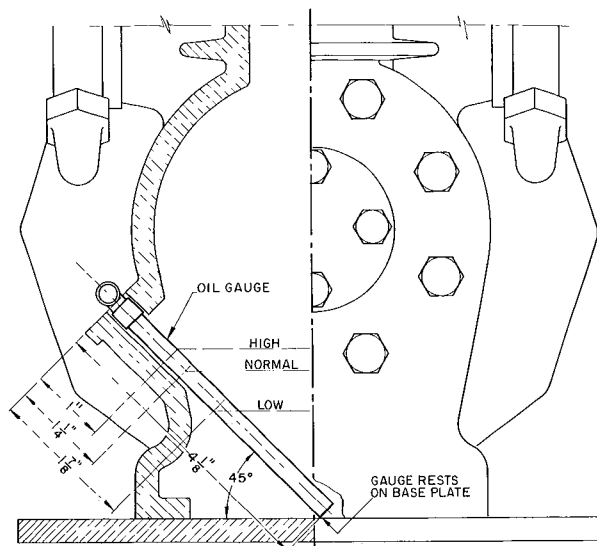

NOTE MEASURE OIL LEVEL AT 45° ANGLE AS SHOWN FROM OUTSIDE FACE OF OIL FILL HOLE. OIL GAUGE CONSISTS OF A 1/4" COPPER TEE SOLDERED TO A STRAIGHT PIECE OF 1/4" COPPER TUBING

FIG. 12 - COMPRESSOR OIL LEVEL

momentarily touch starting lead of cord to "S" on compressor terminals. Do not leave this prong in contact with terminal "S" for more than one or two seconds; otherwise the starting winding will be damaged.

Caution: When using test cord on compressor, stand clear of terminals. If current should arc or terminal break, terminal may blow out with considerable force. An arc might also ignite oil entrained in escaping gas.

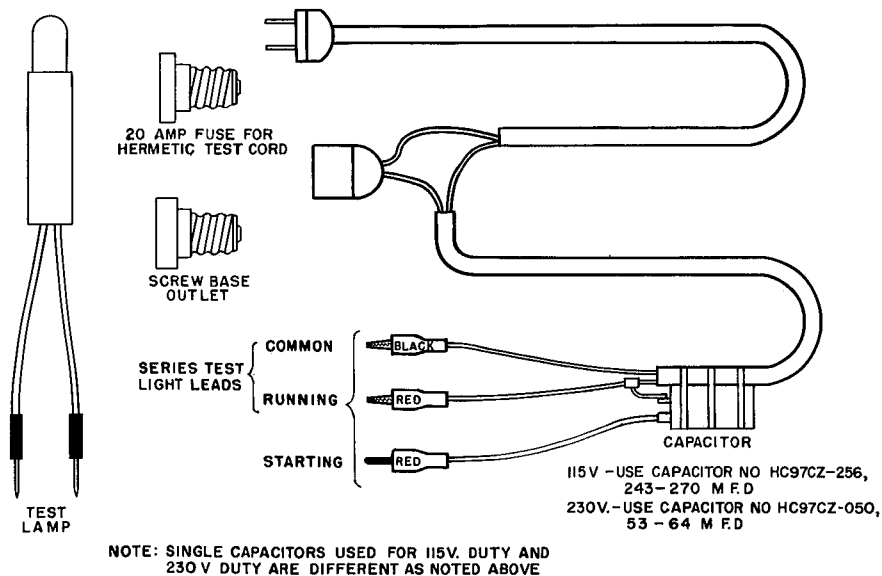

NOTE: SINGLE CAPACITORS USED FOR 115V. DUTY AND 230 V DUTY ARE DIFFERENT AS NOTED ABOVE

FIG. 13 - TEST CORD DIAGRAM

Portable Line Voltage Tester

APPLICATION AND OPERATION - A portable line voltage tester with built-in phantom load which provides a simple means of checking single phase or direct current circuits is shown in Fig. 14. By reading the voltage at no load and the voltage with phantom load it can be determined if the circuit is adequate for starting and operating the unit. The tester is made to Carrier specifications and includes a table for use with ice cube makers.

PHYSICAL DATA

Case Size	8" x 8" x 4"
Voltmeter Scale	0-150 volts (Double Reading for 230V)
Ampere Load	11.5
Voltage	115 - 230
Frequency	25, 50, 60 cycles or direct current
Approx. Weight	5 pounds

Order Directly from
J. & W. Company 290 Roycroft Blvd., Buffalo 21, N.Y.

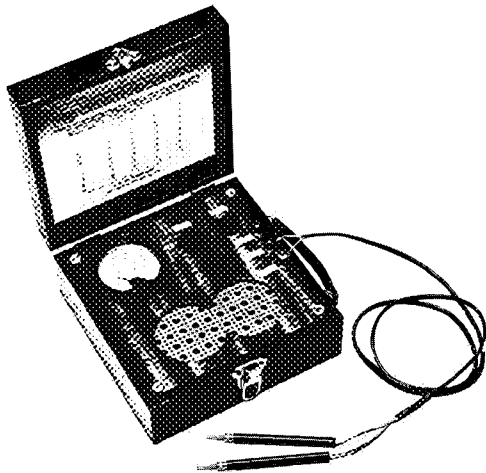

FIG. 14 - VOLTAGE TESTER

COMPRESSOR REPLACEMENT 26H3

To replace the compressor use the following procedure:

1. Purge the refrigerant charge and then front-seat both shutoff valves. Disconnect the suction line flare nut at the shutoff valve. Seal

the suction line with a 1/2" plug to prevent moisture from entering the system.

2. Cut the discharge line and sweat in a 1/4" SAE male copper to flare connection. Cap this connection to prevent moisture from entering the system.
3. Disconnect the compressor leads at the selector switch and thermostat.
4. Remove the four compressor mounting bolts and lift the compressor from the unit.
5. Seal all openings on the compressor to prevent moisture from entering prior to repair or exchange.
6. If compressor failed due to motor burnout, see "Replacement After Motor Burnout".
7. Install the replacement compressor. The replacement compressor is shipped with the discharge line fastened to the suction shutoff valve gauge port by means of a 1/4" flare nut.
8. After completing all wiring and piping connections evacuate and purge the replacement compressor.
9. Charge the unit with refrigerant 12. See Section 4.
10. Before leaving the unit check for leaks.

COMPRESSOR REPLACEMENT 26H5

To replace the compressor, follow this procedure:

1. If the compressor is in running condition, pump down as explained in Section 3.
2. If the compressor is not in running condition close the suction, discharge and oil return shutoff valves and then slowly bleed pressure thru the discharge gauge plug.
3. Check to see that both shutoff valves are frontseated and unbolt them from the compressor. Leave the valves connected to the piping.
4. Disconnect the high pressure line from the discharge side of the compressor.
5. Close the water supply valve and disconnect the compressor cooling coil. The replacement compressor comes supplied with this coil.

6. Remove the compressor terminal box cover and disconnect the compressor motor connections. Mark connections so they may be correctly reconnected to the replacement compressor.
 7. Remove the cotter pins and castellated nuts from the top of the compressor mounting bolts.
 8. Lift the compressor from the unit.
 9. Seal all openings on the compressor to prevent moisture from entering prior to repair or exchange.
 10. If compressor failed due to motor burnout, see "Replacement After Motor Burnout".
 11. Install the replacement compressor. Place new gaskets between all shutoff valves and the compressor flanges.
 12. Make sure the oil level in the replacement compressor approximates oil level in the compressor removed.
 13. After completing the piping and wiring, evacuate and purge the replacement compressor as described in Section 3.
 14. Backseat all valves and start unit.
 15. After operating for at least 2 cycles, check the refrigerant charge as described in Section 4.
 16. Check for leaks. Use a halide torch, soap bubble method or both.
3. Remove strainer-drier from liquid line. Flare liquid line for 1/4" SAE connections.
 4. Install Sporlan Catch-All Type C-162 Strainer-Drier. The 1/4" liquid line coming from near bottom of condenser should be fastened to the inlet side of the Sporlan Catch-All. Direction of arrow should be pointing upwards.
 5. Install new compressor.
 6. Evacuate the entire system as described in Section 8 and add refrigerant as described in Section 4.

The Sporlan Catch-All can be left in the refrigerant circuit. In addition to drying the refrigerant in the system, the molded, porous core of the Catch-All will catch all scale, solder particles, carbon, sludge, dirt or any other foreign matter with negligible pressure drop.

7. LIQUID-SUCTION INTERCHANGER AND ACCUMULATOR REPLACEMENT

26H3

- a. Open the disconnect switch.
- b. Remove all panels.
- c. Slowly bleed the system to the atmosphere as described in Section 8.
- d. Front seat both the suction and the discharge valves.
- e. Unscrew the flare nut at the suction service valve.
- f. Unscrew the flare nut attaching the capillary to the drier and loosen the clamp holding the capillary adapter to the frame.
- g. Unsweat the capillary at the top of the evaporator. The evaporator shroud will not telescope the way it does on the 26H5. Be careful when using a torch near the evaporator as the evaporator tubes are soft soldered to the freezing columns.
- h. Unsweat the suction line at the evaporator. Refer to sections 8 and 4 for evacuating and recharging instructions.

REPLACEMENT AFTER MOTOR BURNOUT

When a hermetic motor compressor burns out, the stator winding insulation decomposes - forming carbon, water and acid. To prevent contamination of the refrigerant system by these products of combustion, the refrigerant circuit must be cleaned when installing a new compressor.

The procedure for cleaning the system is as follows:

1. Disconnect water supply line and drain the water from the condenser, to prevent condenser freeze-up during purging.
2. Purge refrigerant charge.

26H5

- a. Open the disconnect switch.
- b. Remove all panels.
- c. Slowly bleed the system to the atmosphere as described in Section 8.
- d. Front seat the compressor shutoff valves and the oil return line shutoff valve
- e. Unscrew the flare nut at the suction service valve.
- f. Unsolder the liquid line at the entrance to the twin capillary adapter. Exercise care so that the adapter is not oxidized internally by overheating. Telescope the bottom evaporator reflector shroud over the top shroud.
- g. Unswear the two capillaries at the evaporator. Be careful when using a torch near the evaporator as the evaporator tubes are soft soldered to the freezing columns.
- h. Unswear the suction line at the evaporator.
- j. Disconnect the oil return line from the end bell of the compressor motor by loosening the flare nut at the valve.
- k. Remove the compressor. The complete assembly can then be removed. Refer to Section 8 and 4 for evacuating and recharging instructions.

8. DRYER REPLACEMENT

The original dryer has flare connections. See Fig. 10. Slowly bleed the refrigerant charge as follows:

- a. Make sure the suction shutoff valve is backseated.
- b. Remove one of the gauge port plugs.
- c. Slowly turn the shutoff valve off backseat to bleed the refrigerant charge. Bleed slowly to prevent condenser freezeup.

Evacuate the refrigerant system as follows:

- a. Backseat the suction shutoff valve.
- b. Frontseat the discharge shutoff valve.
- c. Remove one of the discharge gauge port plugs, and connect a piece of 1/4" copper tubing about 1 foot long to this gauge port.

- d. Start the machine.
- e. When the amount of gas coming from the 1/4" copper tube has decreased appreciably, immerse the copper tube into a can of refrigeration oil.
- f. The gas being expelled will bubble up through the oil.
- g. After bubbling has ceased it can be assumed the refrigerant system has been evacuated.
- h. Remove the tube from the gauge port, and with the compressor still operating screw in the gauge port plug. Then backseat the discharge shutoff valve and turn off the compressor.

Add refrigerant to the system as described in Section 4 "Refrigerant Charge".

9. CONDENSER CLEANING AND REPLACEMENT

FLUSHING THE CONDENSER WATER CIRCUIT

Scale deposits on the inside of the condenser water circuit can significantly reduce the condenser's capacity and increase the water consumption. If the scale becomes too heavy, the head pressure will increase because of poor heat transfer inside the condenser.

Obtain the equipment shown in Fig. 15.

Set up the equipment as shown in Fig. 16.

Procedure

1. Remove the front panel and turn the selector switch to "Off."
2. Close the water supply line shut-off valve, and assemble the equipment to the unit.
3. Mix a solution of inhibited muriatic acid and water in one of the pails. **ADD THE ACID TO THE WATER.** Mix 1.5 quarts of acid into 3.5 quarts of water.
4. The level of solution in the pail should be at least 2" below the bottom of the pump motor. **AVOID SPILLING ANY SOLUTION.**
5. Start the pump and allow it to run 20 minutes, or until the solution draining back to the pail contains no foam.
6. While running the pump, mix a solution of 1/4 lb. of baking soda in 8 quarts of water.

7. At the end of 20 minutes, turn the pump off and place the pump in the soda and water solution.
8. Start the pump and allow the soda and water solution to circulate for 15 minutes.
9. While the neutralizer is being circulated, fill the pail containing the acid solution with water and then empty the pail in an open drain.
10. Rinse the pail and fill it with water.
11. Turn the pump off and place it in the pail of clean water.
12. Start the pump and allow it to run for 5 minutes.
13. Turn the pump off and break the flare or hose connection at the pump.
14. Lift the pump out of the water, then lift both lines to allow the lines and condenser to drain into the pail.
15. Break the connection at the condenser inlet.
16. Reconnect the condenser inlet line to the water regulating valve.
17. Break the connection on the condenser outlet and reconnect the permanent drain line.
18. Turn on the shutoff valve in the water supply line.
19. Turn the selector switch to "On" and check the connections to see if they are tight.
20. Remove the cleaning equipment and clean around the machine.

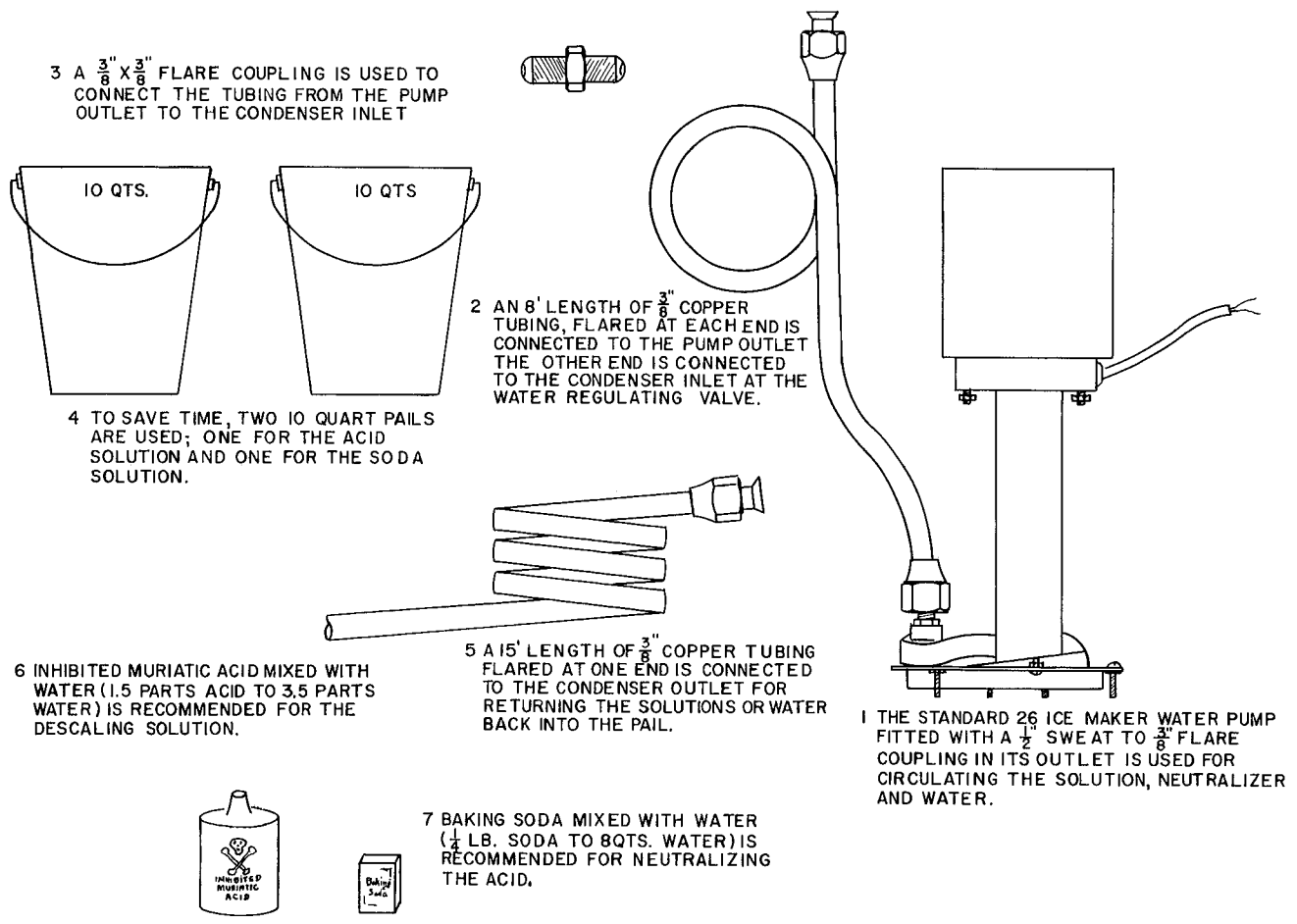

NOTE: AN ALTERNATE TO USE IN PLACE OF THE 8' LENGTH OF COPPER TUBING AND THE $\frac{1}{2}$ " SWEAT TO $\frac{3}{8}$ " FLARE COUPLING, IS TO USE AN 8' LENGTH OF $\frac{1}{2}$ " RUBBER HOSE AND 2 $\frac{1}{2}$ " HOSE CLAMPS

FIG. 15 - REQUIRED FOR CONDENSER CLEANING

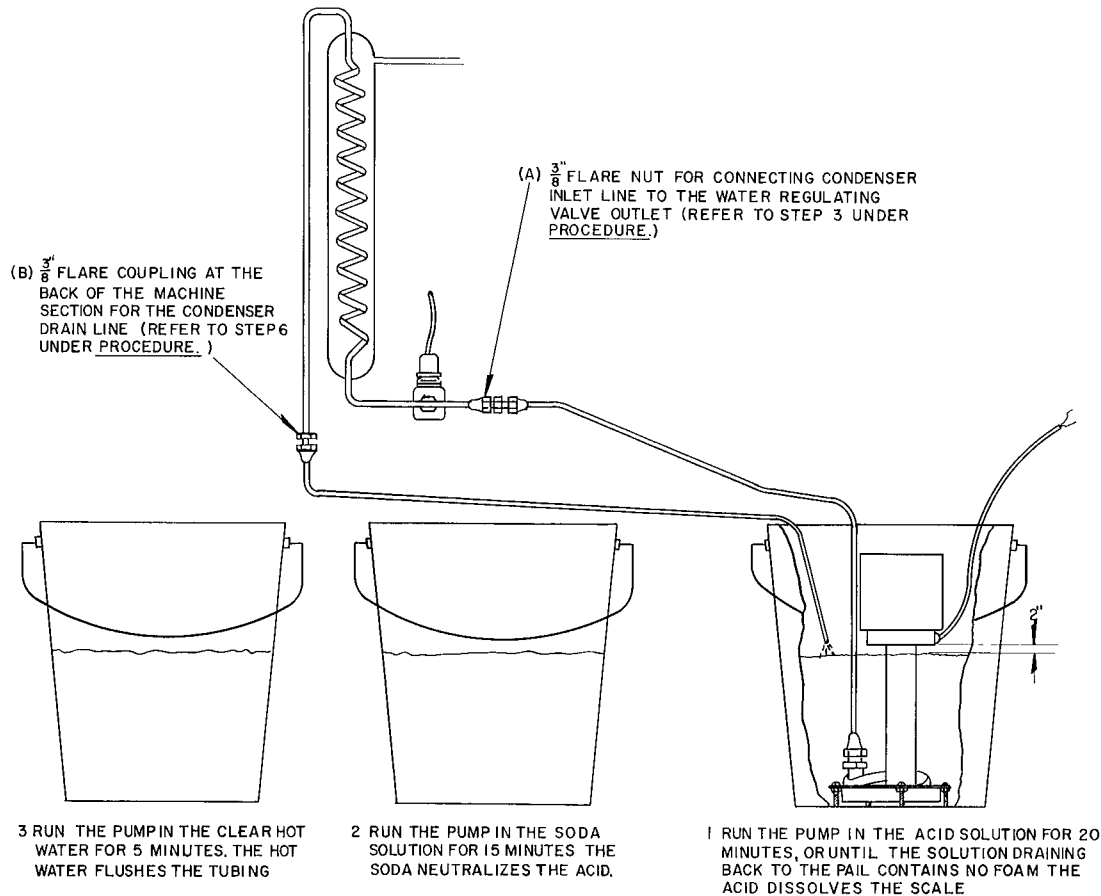

FIG. 16 - CONDENSER CLEANING PROCEDURE

CONDENSER REPLACEMENT

The condenser is mounted in a vertical position on the left side of the unit.

- Close the water supply valve before removing the condenser.
- Remove front, top and left side panels.
- Slowly bleed refrigerant from the system as described in Section 8.
- Unsweet all refrigerant tubing connections while the suction valve is still open. All of these joints are phos-copper.
- The condenser is held by a strap screwed to the unit frame. Lift the condenser up and out.
- After replacing the condenser, evacuate and recharge the system as described in Sections 4 and 8.

10. EVAPORATOR REPLACEMENT

Bulged freezing columns may be indicated by "excessive" defrost time; 4-5 minutes before the first ice drops and 4 minutes or longer before all the ice drops is considered excessive defrost time.

To determine if columns are bulged remove spreader plates (see Fig. 17), and place light under freezing columns and observe from the top of each column. If several columns are seriously bulged and unit has excessive defrost time even with adequate charge, the evaporator assembly should be replaced.

REPLACEMENT PROCEDURE

- Remove front, top and side panels.
- Slowly bleed refrigerant charge as described in Section 8.

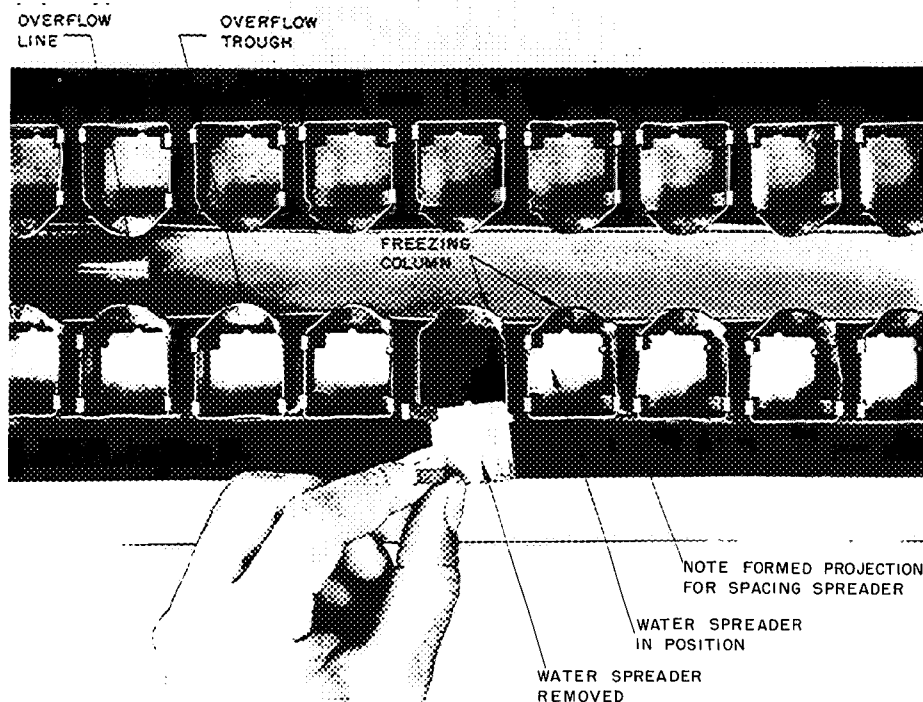

FIG. 17 - WATER SPREADER PLATES

3. During the period of "Blowing the charge", remove screws and clamps from each side of lower evaporator shroud, then lift shroud upwards as far as it will go. Capillary joints are accessible on right side of unit.
 4. Remove water distributor header.
 5. After refrigerant charge is "blown", carefully melt capillary, suction header and hot gas header joints. Pull joints apart while applying heat. On the left side of evaporator, melt water trough overflow and safety overflow which are "soft solder" joints and require very little heat.
- CAUTION:** The capillary suction header and hot gas header joints are Phos-copper which melts at approximately 1400°F. Care should be taken not to "over-heat" the Phos-co joints when melting or making a connection.
6. Remove evaporator support bracket screws and lift evaporator straight up.
 7. Remove all spreader plates. Remove all scale and clean. Place spreader plates in new evaporator assembly.
 8. Position replacement evaporator in unit; fasten supporting brackets.
 9. Make all connections. If Phos-co is not available, silver solder may be substituted. Pliers may be used to guide capillary in place while soldering. Make sure that no hard solder plugs capillaries.
 10. Fasten water header in place.
 11. Check oil level of compressor. Refer to Section 6.
 12. Evacuate the refrigerant system. Refer to Section 8.
 13. Add refrigerant to system. Refer to Section 4.
 14. Machine must be operated for many cycles to check freezing and defrost time. While unit is operating, check for refrigerant leaks. When unit is satisfactory, replace evaporator shrouds and panels.
 15. When replacing the evaporator assembly, the operation of the main control thermostat and the safety overflow switch must be checked.

3. FREEZING WATER CIRCUIT

11. FLOAT VALVE

The float valve, see Fig. 18, meters the make-up water which is circulated to the freezing columns and can be observed by removing the front panel and inner access door.

The float valve can be adjusted by loosening the wing nut and the set screw and adjusting the connecting arm. Raising the float will raise the water level, and lowering the float will lower the water level. The water level should be approximately 1/2" below the top of the siphon standpipe for the 26H5 units, and 3/8" below for the 26H3 units.

CAUTION: After adjusting the float with the set screw, tighten the wing nut. If the float works loose, water will overflow through the siphon standpipe and cause an extremely long freezing time and a continuous siphoning action.

To replace the float valve:

- a. Close the water supply valve.
- b. Remove front panel and inner access panel.
- c. Remove float from valve by taking out wing nut. This float valve can be removed from the front by turning the valve body counter-clockwise.

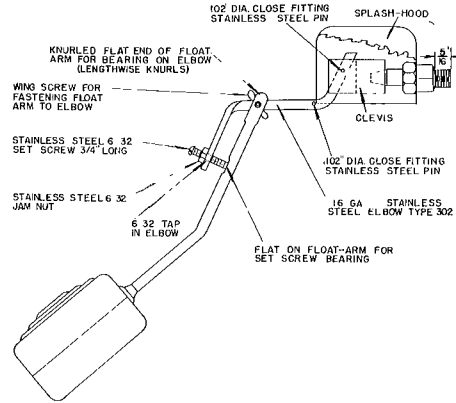

FIG. 18 - FLOAT VALVE ASSEMBLY

To inspect the valve seat and orifice, remove the stainless steel pin, freeing the valve arm from the body.

12. WATER DISTRIBUTOR

The water distributor feeds the freezing columns and should be checked to insure that the discharge nozzles are clear. Water flow from all ports should be approximately the same. To inspect the headers, disconnect the rubber hose (s). Remove the three screws which hold the header assembly and support brackets in place and lift the header from the top of the machine compartment. See Fig. 19.

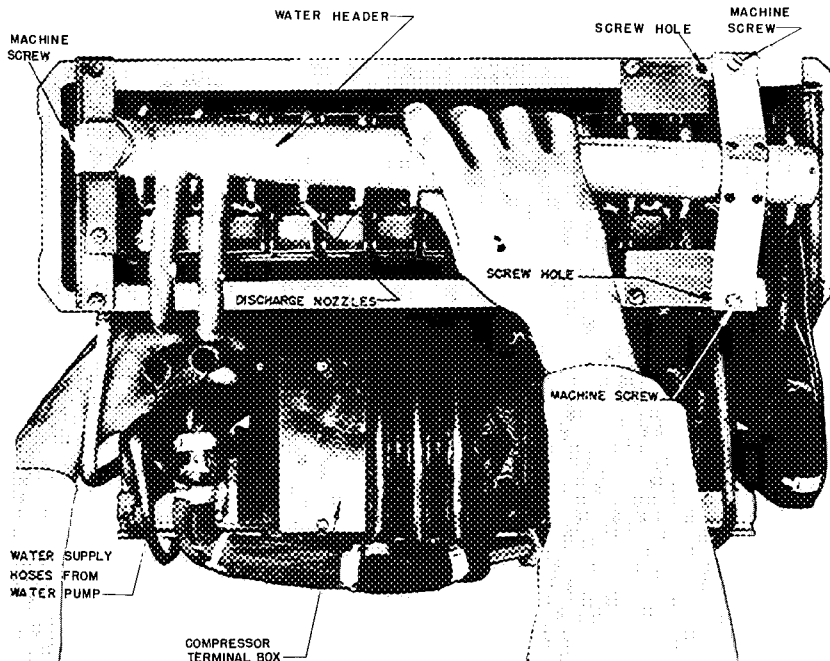

FIG. 19 - WATER DISTRIBUTOR

13. WATER REGULATING VALVE ADJUSTMENT

A 3/8" water regulating valve is used to control the water flow through the condenser. This valve is located in the inlet side of the condenser water system. For best operation and maximum ice production the head pressure should be maintained at approximately 125 PSIG for 26H5 and 130 PSIG for the 26H3. This is equivalent to approximately a 20° rise in condenser water temperature. Head pressures below 125# and 130# respectively will increase the harvesting cycle due to insufficient hot gas for defrost. Head pressures above those recommended will increase the freezing time and may overload the compressor. Adjust the water regulating valve by turning the notched ring. See Fig. 20. A quarter turn will change the head pressure approximately 5 PSIG.

A defective water regulating valve can be removed without breaking the high pressure connection by removing the screws which hold the bellows bonnet in place. If it is necessary to replace the bellows, pump down the compressor as explained in Section 4.

14. WATER TREATMENT

During the freezing cycle, only pure water is frozen into cubes and removed from the water circuit. Accumulated impurities remain in the system and may eventually cause scaling. Various water softeners are on the market but none of these, except a costly total demineralizing process, are sufficiently effective.

The concentration of minerals is decreased by the siphon heat interchanger. The sump is flushed out at the end of each freezing cycle and filled with fresh water. This flushing process does not eliminate the necessity of cleaning the unit, but it does decrease the number of times per year this cleaning is necessary.

In some localities the amount of suspended matter in the supply water may cause trouble. To cut down the amount of impurities entering the system, install a water filter in the water supply line before the interchanger. The filter should be checked at each inspection call and the filtering cartridge replaced if it obstructs the flow of water.

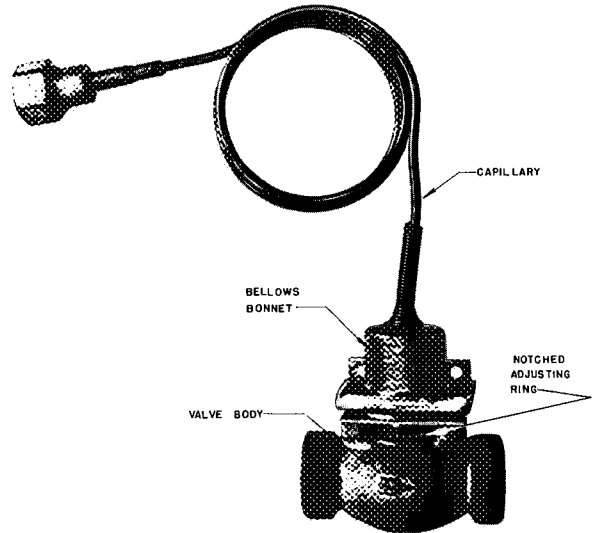

FIG. 20 - WATER REGULATING VALVE

15. WATER SYSTEM CLEANING

The frequency and the amount of cleaning will vary depending on the mineral content of the water supplied.

At least once a month the water compartment should be flushed by removing the siphon standpipe. When extensive cleaning is required, proceed as follows:

1. Turn off the ice maker; close off the water supply line.
2. Remove the access panel and the inner access door.
3. Remove the ice deflector.
4. Drain the water pan.
5. Inspect the parts removed and the water pan for signs of scaling. The amount of scaling can be decreased by more frequent flushing.
6. Remove the top panel and water header to check for deposits on the spreader plates.
7. If a water filter is used, check the filter element for dirt or other foreign deposits. Replace the element if necessary.
8. Clean the water pan panels and deflectors by using a wire brush, soap and hot water.
9. The spreader plates can usually be cleaned by using a knife to dislodge the scale. If this is not possible, then the spreader plates must be removed for cleaning.

10. In cases where light deposits of scale are found circulate a vinegar and water solution (1 quart of vinegar to a full water pan) and operate the water pump separately by turning the selector switch to "Pump" position. Circulate 20-30 minutes, drain, open the water supply line and flush twice.

11. For heavy scale conditions, first remove all ice from bin. Mix inhibited muriatic acid solution as described in Section 9.

Circulate approximately 20 minutes, drain and flush.

12. Then circulate Baking Soda solution for 10 minutes, drain and flush.

13. To clean algae from the water system, use hydrogen peroxide mixed with equal parts of water. Circulate for 20 minutes. Pour some solution into overflow trough and flush the system.

14. Start up the unit and time it through one complete cycle. While doing this, clean out the bin by using soap and warm water or a cleaning solution approved by local health codes. Flush out the bin after cleaning.

15. Catch the ice from the first harvest and throw it away. At every inspection, steps 1 through 7 should be followed. Steps 8 through 15 should be followed if required. Local health codes should be observed.

When cleaning the water system, pour some of the solution into the evaporator overflow trough and allow it to flow into the overflow well. Allow it to remain in the overflow well for 20 - 30 minutes, then flush with the same solution used to flush the water system. Check the main control capillary and wipe if necessary.

16. WATER PUMP LUBRICATION

The water pump is equipped with oil tubes and should be oiled with a few drops of SAE 20 motor oil, every ninety days.

CAUTION: *DO NOT* drop oil in the water pan - it will adversely affect the freezing process.

The oiling instructions are prominently displayed on the pump:

OIL TWO BEARINGS EVERY 3 MONTHS

USE NO. 20 UNTREATED MOTOR OIL

DO NOT OVER-OIL

DO NOT LET OIL GET INTO THE WATER

17. TESTING AND REPLACING THE WATER PUMP

The water pump, with a built in overload, is powered by a 1/30 HP totally enclosed motor and circulates approximately 10 gallons of water per minute in the 26H5 and 5 gallons per minute in the 26H3. The 26H5 pump has two outlets and the 26H3 one which causes the difference in the rate of flow.

Remove the front, top and left side panels to gain access to the pump. See Fig. 21. To test, attach a test cord directly to the pump leads. To replace, remove the mounting plate screws and splash deflector panels and lift the pump assembly out of the water compartment.

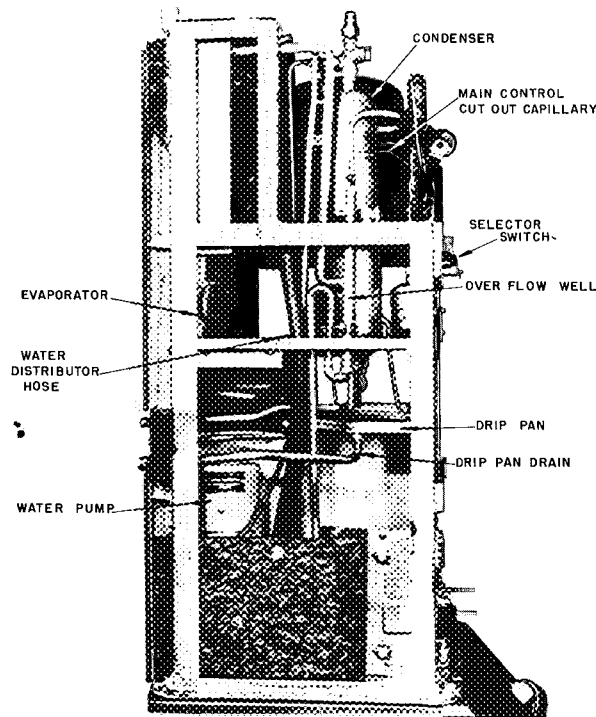

FIG. 21 - LEFT SIDE OF 26H3 MACHINE SECTION - PANELS REMOVED

18. VARIATION OF CUBES

Usually 18% of the cubes will vary from the standard as follows:

- 1. Due to the slight taper of the freezing column the cubes formed in the bottom will have a larger external dimension than those formed at the top.
- 2. The top and bottom cubes in each column will have a slightly larger hole than those in the center.
- 3. The first column to freeze nearly shut, thereby causing water to overflow and end the freezing cycle, will produce one or more cubes with smaller holes.

19. CRUSHER

CRUSHER GUARD

The same crusher guard assembly may be used for bins with and without partitions. It is necessary, however, to adjust the position of this assembly depending on whether or not the partition is used. Refer to Fig. 22 which shows the crusher guard and also explains how to install it.

CRUSHER LUBRICATION

The crusher and the crusher motor require periodic lubrication. Fill the cups with SAE 20 oil (approximately every 6 months). The crusher is equipped with oilite bearings both front and rear, and since the rear bearing carries the load, there is an oil tube leading to it. When oiling the crusher motor, put 10-15 drops of oil in the oil tube leading to the crusher rear bearing.

REMOVAL OF CRUSHER

The crusher assembly is removable from the front of the unit. First open the main disconnect switch. Remove the control knobs, both front and side panels, the inner access door, ice deflector, splash curtain and the side baffles. Remove the galvanized channel and the screws along the top edge of the crusher. Remove the screws at the base of the crusher. A removable stainless steel clip is used to hold the water pan and ice crusher housing together.

When replacing the crusher switch-knobs, make sure they are positioned to agree with the printed decal markings.

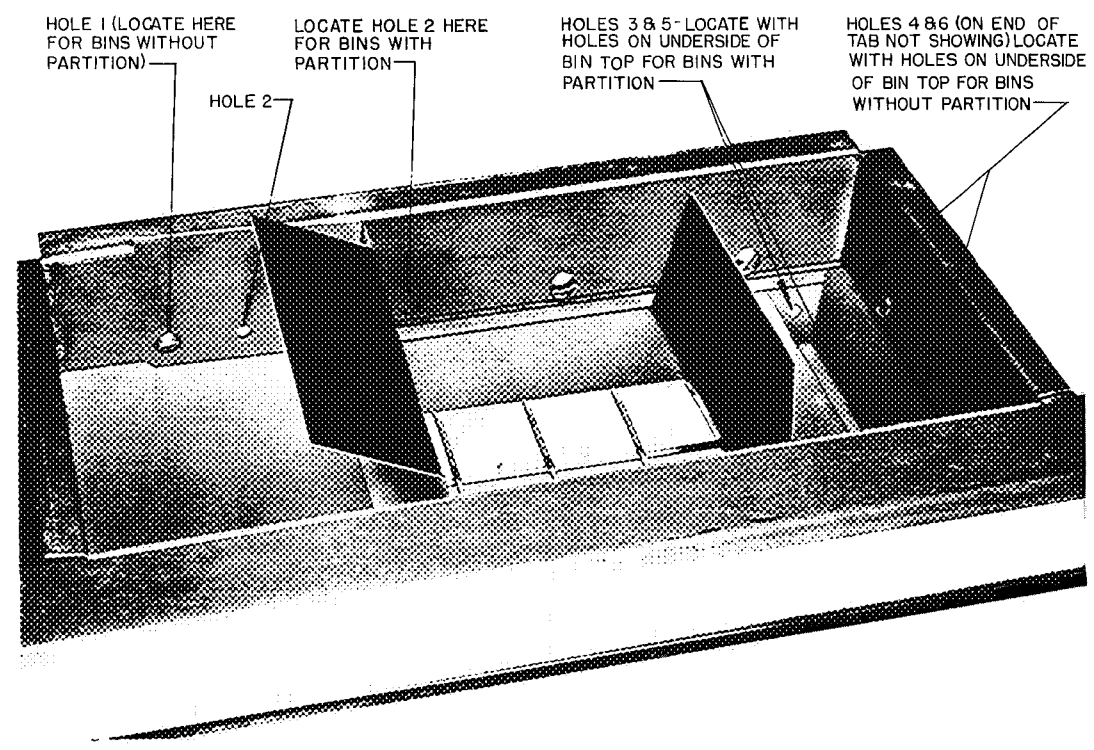

FIG. 22 - CRUSHER GUARD ASSEMBLY



TROUBLE ANALYSIS

To have the crusher operate, the following conditions are necessary:

1. Three-position selector switch in "Pump" or "On" position. Power supply to unit OK.
2. Safety switch in closed position. Panel must depress switch arm to make contact.
3. Damper switch in "Crushed" position.

4. Main control in harvest cycle.

NOTE: Early models used a relay, and crusher ran whenever unit was off on bin thermostat. On later units crusher runs when unit is off on bin thermostat only, until main control warms up and goes to "Freeze" position.

If the above conditions are fulfilled and the crusher still does not operate, the wiring and the various controls should be checked with a test light.

4. ELECTRICAL CIRCUIT

20. CHECKING VOLTAGE

Check the outlet voltage. It should be within 10% of the nameplate voltage. Try to make this test when the voltage is likely to be the lowest; that is, when the power line is carrying the heaviest load.

Low voltage may prevent the unit from starting, or if it is running, may cause the compressor to overheat and cutoff on the motor overload. Low voltage can also result in bulged evaporator columns due to failure of the hot gas solenoid to open.

Refer to Section 13 in the Installation Section concerning a voltage transformer for increasing the power supply to the unit.

21. LOOSE TERMINALS

Loose terminals will cause erratic operation. With the disconnect switch opened, check the terminals of the selector switch, relay, thermostats, solenoid valve, water pump and compressor to make certain they are tight.

22. SELECTOR SWITCH

A rotary type selector switch is located under the the hinged nameplate. This switch is in series

with one lead from the power supply. **CAUTION:** In the "Off" position the switch cuts power from only one of the power supply leads. Therefore, open the disconnect switch when servicing the unit.

If the main control is in the "defrost" position the water pump will not operate when the selector switch is in the "pump" position.

To gain access to the switch terminals, first remove the indicating knob and hexagonal nut which secures the switch to the bracket. Check the operation of the switch with a test lamp.

23. CONTROL BOX

COMPRESSOR TERMINAL BOX 26H3

The compressor terminal box houses the starting relay, the motor compressor terminal block, and the motor overload. To gain access to the box interior, remove the slotted screw in the front of the box cover.

26H5

The control box houses the starting capacitor and the starting relay. It is located at the front of the machine.

To gain access to the box interior, unscrew the wing nut and slide the door to the left.

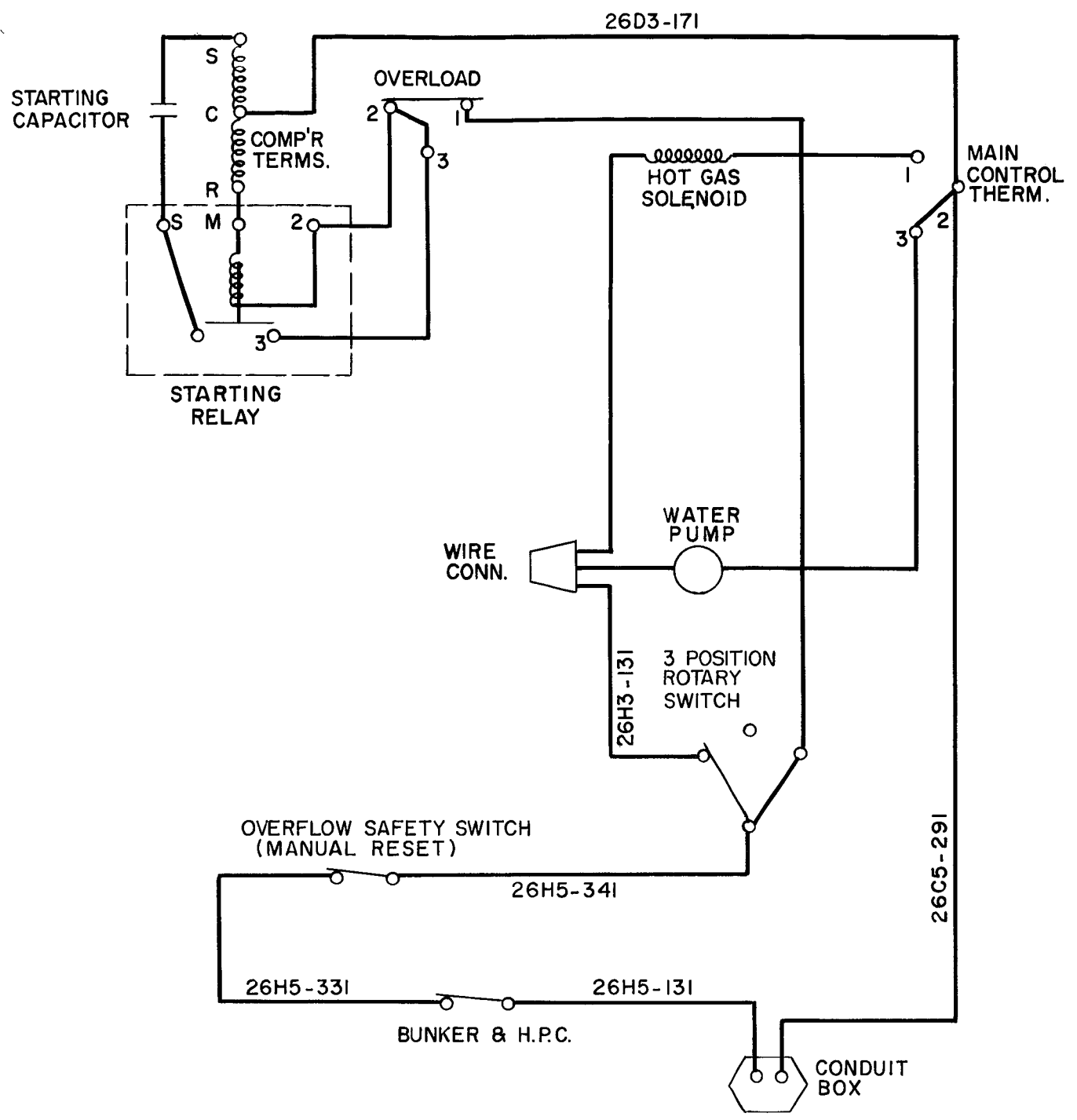

FIG. 23 - 26H3 UNIT 115 VOLT, 60 CYCLE, 1 PHASE
WITHOUT CRUSHER

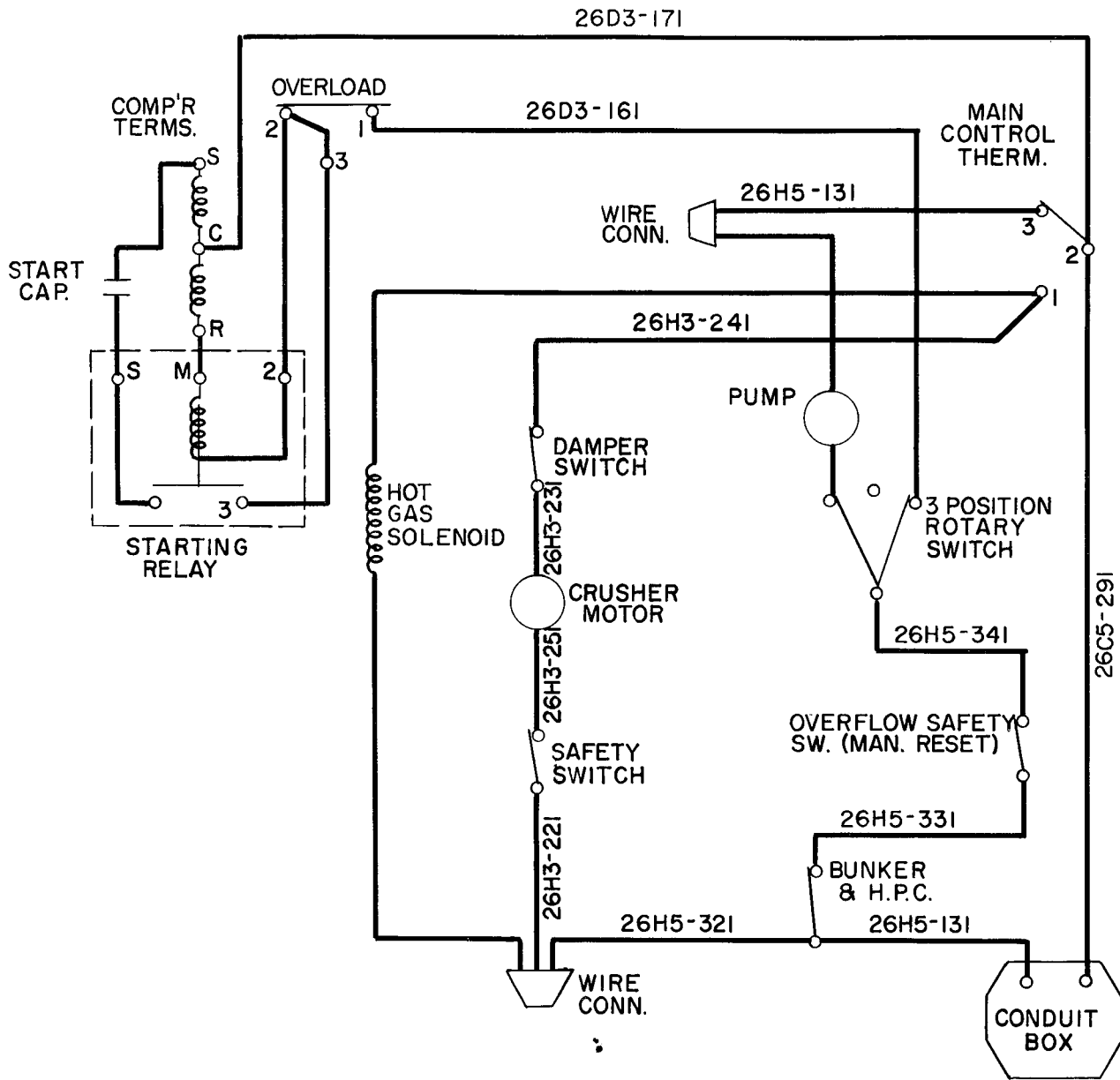

FIG. 24 - 26H3 UNIT 115 VOLT, 60 CYCLE, 1 PHASE
WITH CRUSHER

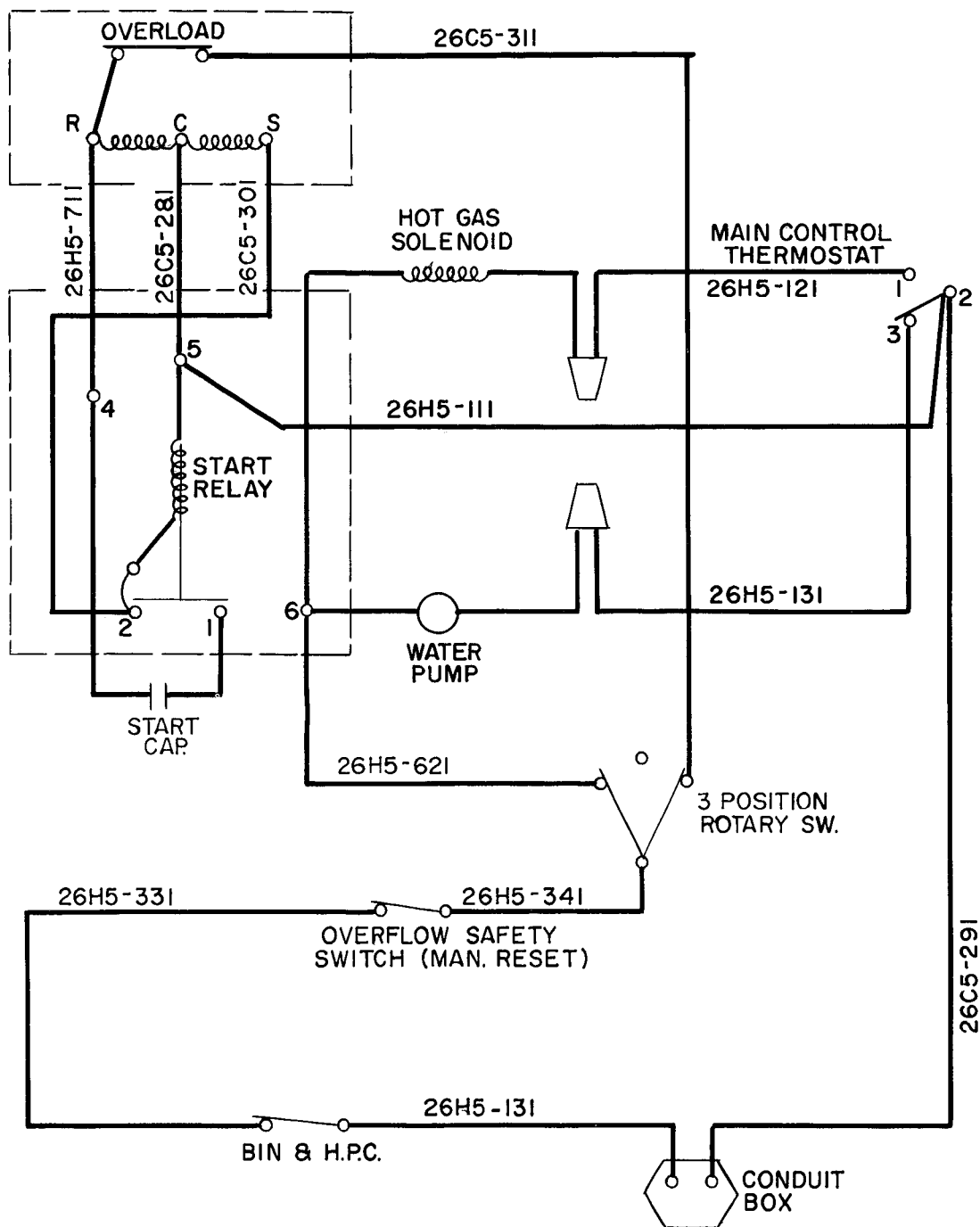

FIG. 25 - 26H5 UNIT 115-230 VOLT, 60 CYCLE, 1 PHASE
WITHOUT CRUSHER

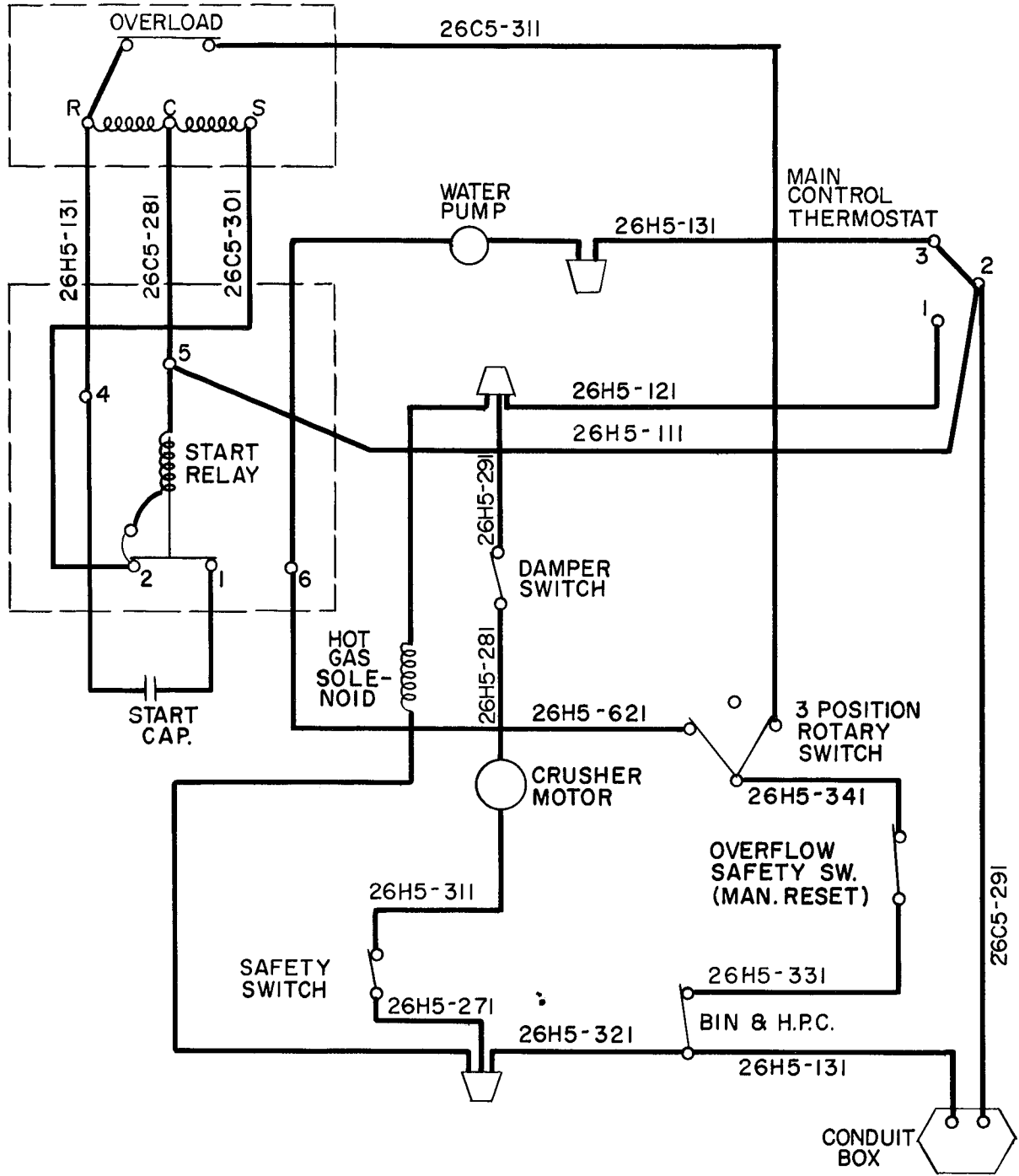

FIG. 26 - 26H5 UNIT 115-230 VOLT, 60 CYCLE, 1 PHASE
WITH CRUSHER

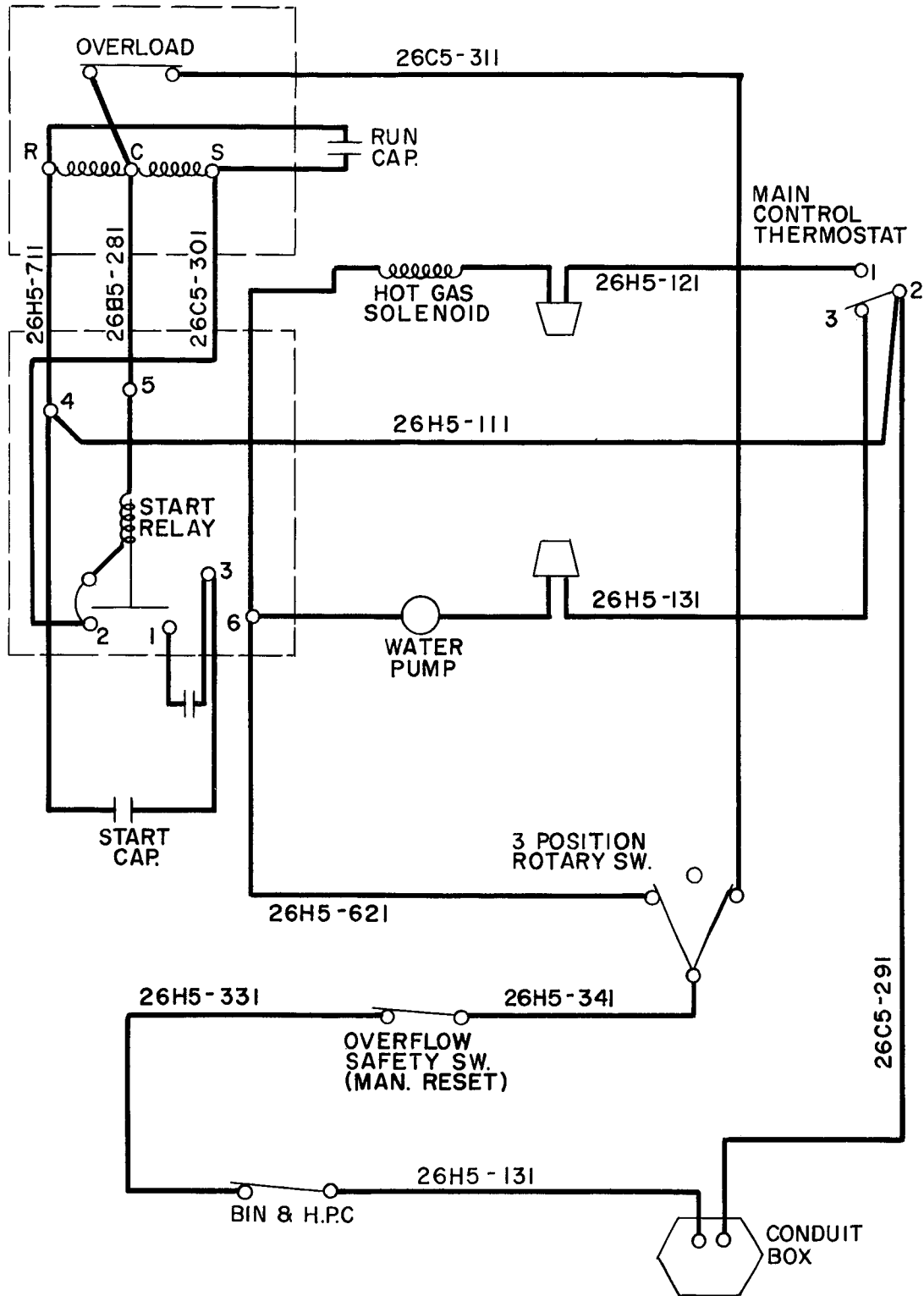

FIG. 27 - 26H5 UNIT 230 VOLT, 50 CYCLE, 1 PHASE
WITHOUT CRUSHER

24. CAPACITORS**26H3**

A 158-191 MFD capacitor, located on the compressor above the terminal box, is used on the 26H3 115V compressor.

26H5

A 243-270 MFD starting capacitor is used on the 115 volt units. A 53-64 MFD capacitor is used on the 230 volt units.

A capacitor may fail because of a short circuit or an open circuit. If short circuited, the starting current will be excessive.

The compressor may not start and will be responsible for blowing fuses or dimming lights. If the capacitor wiring is open circuited, no current will reach the starting winding and the compressor will not start.

To check the starting capacitors, disconnect the old capacitor and substitute a new capacitor. If the unit starts, the old capacitor is faulty and should be discarded.

25. RELAY**26H3**

The current type relay is housed in the compressor terminal box. It permits the compressor starting winding to be energized for about 3/5 of a second when the compressor is started. The locked rotor surge of current energizes a magnetic coil closing a set of contacts and completing the starting capacitor circuit to the compressor starting winding. As the compressor speed increases, the initial locked rotor current surge decreases, the magnetic coil is de-energized, the contacts are opened, and the starting capacitor circuit is removed from the compressor starting winding.

26H5

The voltage type relay energizes the starting winding of the motor when the compressor is started until it comes up to speed. After the motor comes up to speed, the windings induce voltage back into the starting circuit of the relay. This "back EMF" is passed through a magnetic coil, which opens the relay contacts and cuts off the power to the starting winding. When the compressor is stopped, a spring pulls the contacts together again.

RELAY CONTACTS STUCK OPEN

If the relay fails with the contacts open, no current will reach the starting windings. The compressor will hum, but will not start. After 15 or 20 seconds, the motor overload will cut off the power to the compressor. After approximately 30 seconds, the overload will turn the power on again. If the relay contacts are still open, the overload will cut off the power again after another 15 or 20 seconds. This cycle will repeat itself until the condition is remedied. Replacement should be made immediately since continued cycling may cause serious damage to the unit. To test for relay contacts stuck open, connect the power supply and turn the selector switch to the "on" position. Momentarily touch a jumper to relay terminals 1 and 2 on the H5, (3 and the unmarked terminal on the H3) until the compressor has a change to come up to speed. **CAUTION:** Do not keep the jumper across these terminals for more than an instant; otherwise, the starting winding will be damaged.

RELAY CONTACTS STUCK CLOSED

If the relay fails with the contacts closed, the starting windings will continue to be energized after the compressor has come up to speed. The compressor will start, but will run with a loud grinding hum. After approximately eight seconds, the overload will cut off the unit. Approximately 30 seconds later the overload will turn the power on again. If the relay contacts still fail to open, the overload will cut out after another eight seconds. This cycle will repeat itself until the condition is remedied.

To test for relay contacts which remain closed, remove the nut from terminal "S" on the compressor terminal board. Connect the unit to the power source and turn the selector switch to the "on" position. As soon as the compressor has started, immediately remove the wire from terminal "S". If removal of the wire makes the unit operate quietly, and without stopping, while attaching the wire makes the unit operate noisily and cut off on the overload, then the relay contacts are stuck closed and the relay assembly should be replaced.

26. COMPRESSOR MOTOR OVERLOAD

Remove the top panel and the top of the compressor terminal box to reach the overload in the 26H5. The 26H3 terminal box is accessible simply by removing the front panel and terminal box cover.

This thermal overload element will open the circuit when overheated and cut off power to the compressor. When the compressor cools off, the thermal element cools slowly and starts the compressor again. Thus, an overloaded compressor will stop for an interval, then restart and, after running a while, will stop again. If a unit is starting and stopping due to the motor overload, immediate steps should be taken to locate and remedy the cause, since continued cycling may damage the compressor. Overloading may be due to low voltage, loose terminals, faulty relay, or causes connected with the refrigerant circuit.

It is possible to determine if current is flowing through the motor overload by testing at the compressor terminals. Turn the selector switch to "on", and place the prongs of a current tester on terminals "R" and "C" of the compressor. A light will indicate the current is flowing through the overload and that it is functioning properly. No light when the compressor is cool (approximate room temperature) will indicate that the overload is stuck open and should be replaced. No light when the compressor is hot will indicate that the overload may be functioning properly, but has cut out due to overloading the compressor.

27. CRUSHER ELECTRIC CIRCUIT

Figs. 24 and 26 are schematic wiring diagrams of the 26H3 and 26H5 crusher-equipped Ice Makers respectively.

CRUSHER MOTOR

This is a 1/6 horsepower 115/230 volt motor. Oil twice a year with standard SAE 20 motor oil.

To replace the motor, remove the crusher assembly as explained in Section 19. The motor is held in place with two bolts and a retainer plate. When mounting the replacement motor, carefully line up the two pulleys and tighten the belt so that it can be depressed 1/4" with the pressure of one finger.

CAUTION: Excessive belt tightness will cause the rear crusher bearing to overheat, lose its oil and become scored.

SAFETY SWITCH

A normally-open safety switch is in the crusher wiring circuit. When the front panel is removed, this switch breaks the circuit to keep the crusher from operating and possibly causing injury.

The access door has a printed warning to open the main disconnect switch whenever servicing this unit. Do not ignore this warning! The safety switch is provided for added protection.

This switch can be removed by removing two of the machine screws which hold it in place and disconnecting the wiring. When replacing this switch, be sure that the front panel depresses the safety switch arm to close the switch contacts.

DAMPER SWITCH

The damper switch opens the circuit to the crusher motor when engaged by an arm of the damper linkage. When the damper is moved to the "crushed" position, the damper switch completes the crusher wiring circuit.

28. CONTROLS

MAIN CONTROL THERMOSTAT

A Ranco two-bulb, single-pole double-throw switch is used on the 26H series Ice Makers. This is an interlocking type of control; that is, when it cuts out on the bulb in the overflow well, it can cut in only from the bulb on the suction line and vice versa. The cut out side of this control is set at 38°, and the adjustment is locked. The cut in side of this control is adjustable, and the setting should be raised if the time between the dropping of the last ice cube and the start of the freeze cycle is less than 30 seconds. The setting may be lowered if the time between the dropping of the last cube and the start of the freezing cycle is more than 1-1/2 minutes. Unless maximum capacity is required, an overrun time of 1-1/2 minutes to 3 minutes is not serious enough to warrant adjusting the control. The cross ambient bulb on the cut in side provides control by bulb only, thus the capillary and bellows are not affected by ambient temperature and this control will operate properly at ambient air temperatures of between 50° and 100°F.

This thermostat cycles the unit from freezing to defrost. At the end of the freezing cycle, water from the freezing columns overflows into the control bulb well. When this happens, the cold water actuates the thermostat, which stops the water pump and energizes the hot gas solenoid valve, thus starting the defrost cycle. The capillary leading from the overflow well to the Ranco control actuates only the cutout side of this control. As

the hot gas passes through the hot gas solenoid into the evaporator and then to the accumulator, it warms the cut out capillary which closes the cut out side of the control. The hot gas also warms the suction line. When the vertical portion of the suction line leading from the accumulator, to which the cut-in bulb is attached, becomes warm, it actuates the cut-in side of the control which closes the hot gas solenoid valve and starts the pump.

PROCEDURE TO CHECK OUT MAIN CONTROL THERMOSTAT

1. Shut off machine and allow bulbs to warm up (about 5 minutes). Platens* should rise to top position. If they do not, a bulb has lost its charge.
2. Turn on machine. Right platen should drop in a few minutes. If it does not, check for low refrigerant charge.
3. Thirty to forty minutes after start of freezing cycle, water should back up into the overflow trough and drop into the overflow well. Left platen should drop, pump stop, and solenoid open. If not, check for restricted water path to control bulb well, algae or dirt in well, and proper placement of left control bulb element in well.
4. The left platen should rise soon after the start of the defrost cycle. Right platen should rise a few minutes later and switch machine to next freezing cycle. Condenser water should not flow during defrost cycle. Check the overrun time.**

* Platens - Hinged plates (inside control) actuated by control bellows.

** Overrun time - period between falling of last ice cube and start of next freezing cycle. Should average 1/2 to 1-1/2 minutes. To increase this time, raise the setting of the right hand (cut-in) element.

WARNING:

High ambient temperature, high water temperature and/or high head pressure will result in a reduction in over run time. If the main control is set at low or normal temperatures and pressures, allow sufficient over run time to avoid trouble in case of an increase in any of the conditions mentioned above.

If the controls are set for an over run time of 90-150 seconds at a temperature of 50° Air and 45° Water, an increase in Air temperature to 80° and an increase in Water temperature to 80° will result in an over run time of 30 - 45 seconds.

29. SAFETY OVERFLOW

The safety overflow is installed on a 26H Icemaker to protect the machine against bulged columns. If the machine fails to go into the defrost cycle, more tubes in the evaporator will overflow, causing the water level in the overflow trough to rise and run out the upper overflow connection into the float chamber, thus causing the float to trip the machine off.

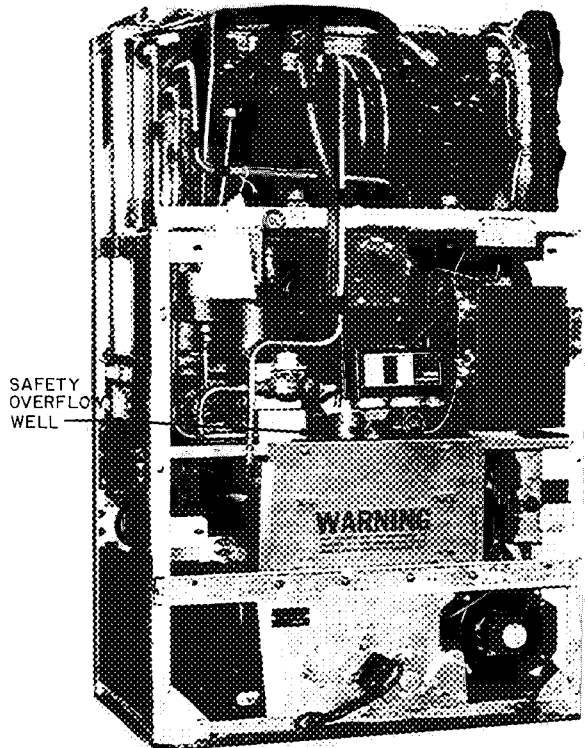

FIG. 29 - FRONT OF 26H5 MACHINE SECTION

30. BIN THERMOSTAT

The bin thermostat shuts off the unit when the storage compartment is full of ice. See Fig. 30. It is a single-pole single-throw switch in series with one lead from the selector switch. The thermostat is accessible after removing the front panel and is in the same casing as the high pressure switch. When servicing the control, remove the control with the holding bracket. It is possible to disconnect

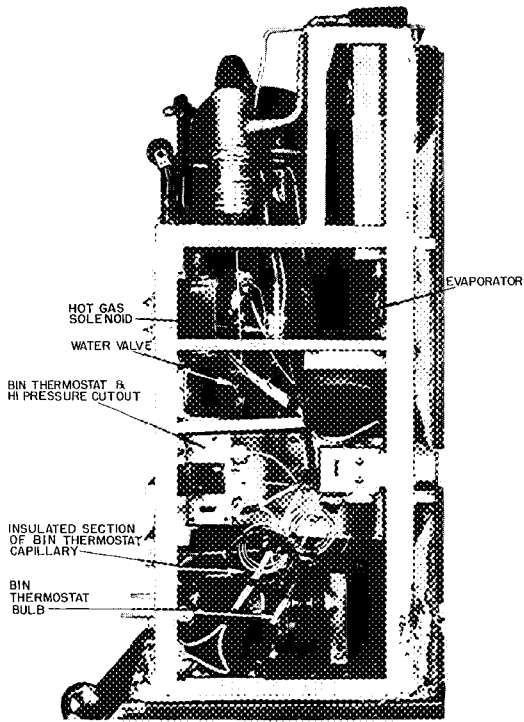

FIG. 30 - RIGHT SIDE OF MACHINE SECTION

the bin thermostat power element from this control and change the control mechanism without disturbing the refrigerant system. If the thermostat bulb is damaged, it also can be replaced separately. The unit will not operate if the thermostat bulb has lost its charge.

The control bulb of the bin thermostat is mounted on a bracket near the top of the storage compartment, or on the bin partition if one is used.

When the ice in the compartment comes in contact with the bulb or capillary, the unit shuts off and remains off until some of the ice is removed. This control can be checked by holding two ice cubes in contact with the bulb clamp as shown in Fig. 31. The unit should shut off in 30 to 45 seconds. The cut-in point should be approximately 41° for most installations, and a differential of 7° should be maintained.

The cut-in and cut-out temperatures may be adjusted by turning the knurled knob on the control. When turning this knob, the differential remains fixed. To

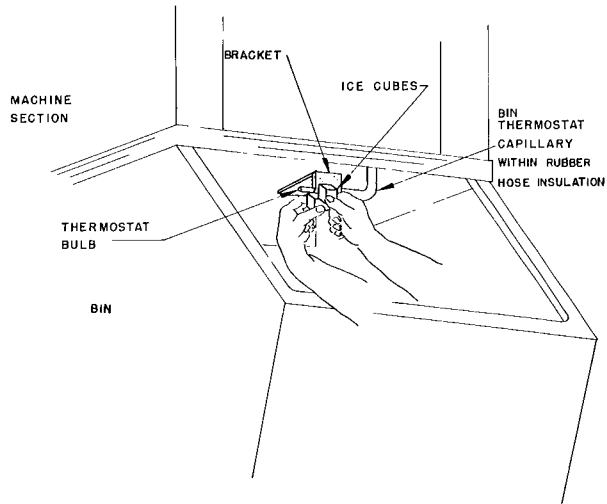

FIG. 31 - METHOD OF CHECKING BUNKER THERMOSTAT SETTING

adjust the differential, remove the knurled knob and small holding plate at the top of the control, and turn the middle adjusting screw.

CAUTION: The room ambient temperature must be above 50°F for this control to function properly.

WITHOUT PARTITION

The bin thermostat should be clamped to the back of the bracket as shown in Fig. 32. The clamp is attached to the bracket at the bottom hole for 240# bins and at the top hole for 160 and 100# bins. The thermostat capillary should run up to the top of the bin liner along the back of the bracket to protect it from water and ice coming from the crusher.

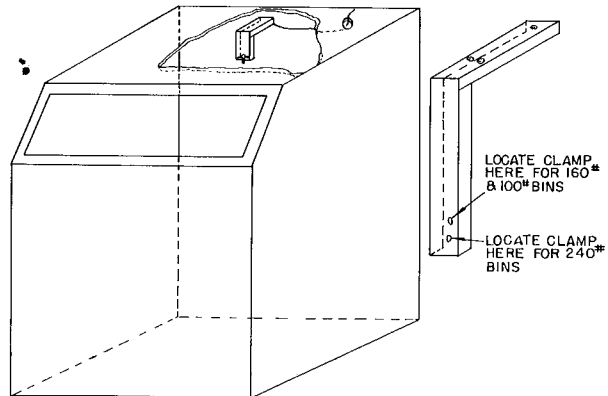

FIG. 32 - SKETCH SHOWING BRACKET AND BIN (WITHOUT PARTITION).

WITH PARTITION

Attach brackets to partition as shown in Fig. 33 and install the partition, Fig. 34. Run the capillary along the top of the bin liner, down the crushed ice side of the partition and then over the top of the partition to the cube side.

31. HIGH PRESSURE SWITCH

This switch stops the unit if the head pressure exceeds 220 ± 7 PSIG. It is located in the same casing as the bin thermostat. This cut-out point is set at the factory and cannot be changed in the field.

NOTE: On start up the unit may cycle on and off several times due to high head pressure. This is normal. The number of times the unit cycles can be decreased by turning the unit to "pump" for a half minute and then restarting.

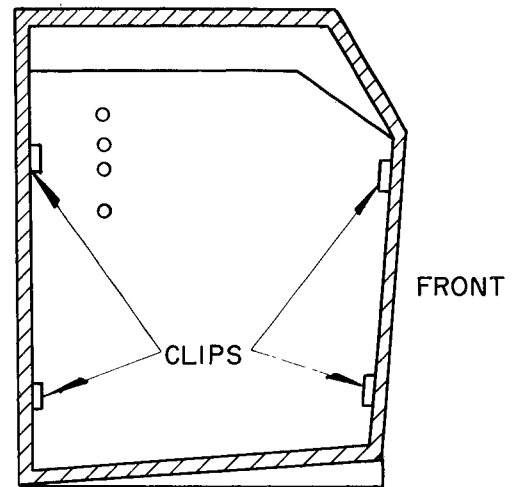

FIG. 33 - SKETCH SHOWING BRACKET ATTACHED TO PARTITION

In replacing this switch the entire control must be changed. Pump down the compressor as explained in Section 4.

240, 160 & 100 LB. BINS

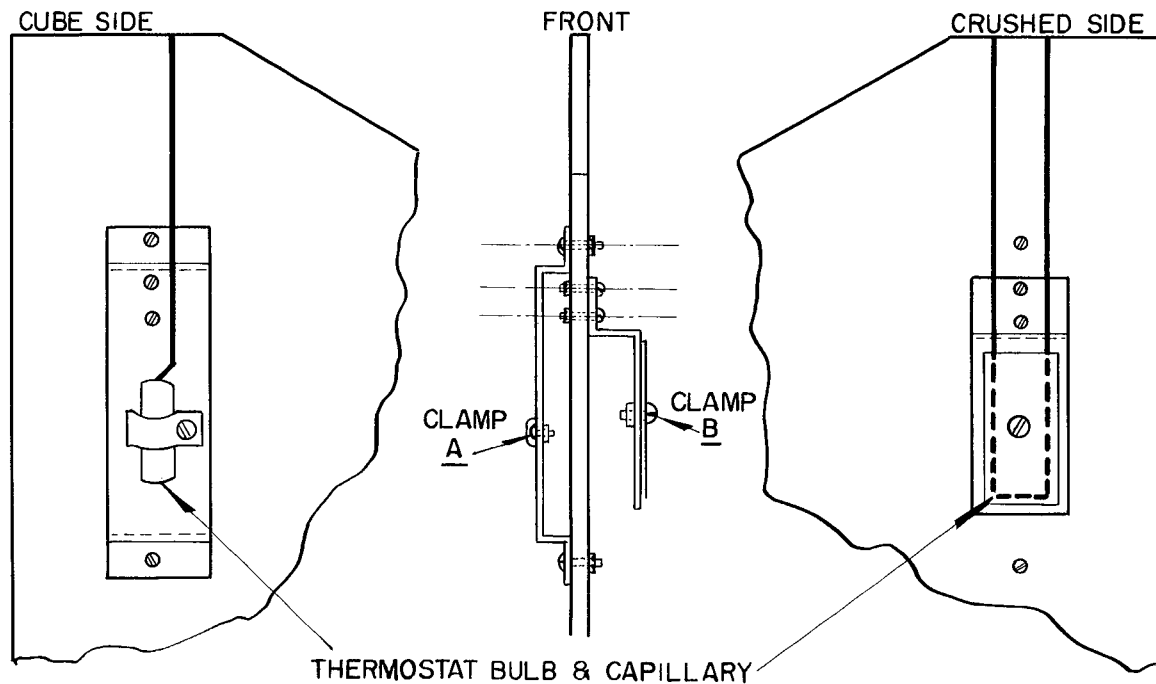

FIG. 34 - SHOWING PARTITION INSTALLED IN BIN

32. TESTING THE SOLENOID VALVE

The solenoid valve passes hot discharge gas to the evaporator during the harvesting portion of the cycle. It is energized by the main control thermostat only during the defrost cycle.

If, upon completion of harvesting, the valve fails to close or closes only partially, the discharge side of the valve will remain warm and little or no freezing will occur in the evaporator. If, on the other hand, the valve fails to open, no harvesting will occur and the ice cubes will remain frozen in the evaporator. To determine whether power is reaching the valve, connect a test light across the leads to the valve. A lighted lamp indicates power is supplied to the coil. The opening and closing of the valve can be heard when standing next to the machine. This will indicate whether the valve is operating but will not prove whether the valve is seated. A hissing noise at the valve indicates a poorly seated valve. Poor seating of the valve will result in excessive freezing time. Malfunctioning of the valve may also be due to low voltage or poor electrical connections.

The solenoid coil (and the valve stem on Sporlan Valves) can be replaced without taking the valve body from the system; however, if necessary, the entire valve can be removed by slowly bleeding the refrigerant charge as described in section 8, and unsweating the connections. Dismantle the replacement valve and cover the body with wet cloths before brazing to prevent damage to the valve. Silver solder is used on the connections. State required voltage when ordering a replacement solenoid valve or coil since the 115 volt and 230 volt coils are not interchangeable.

WINTERIZING ICE MAKERS

For proper operation of the controls, any units which are operated through the winter season should be located where the temperature will not fall below 50°. Where a unit is shut down during the winter season, certain precautions are required if the temperature surrounding the unit falls below freezing.

The unit may be damaged if the following precautions are not taken:

1. The Ice Maker should be cleaned and descaled before shutting down for the winter.
2. Disconnect inlet water supply line. Drain water pan by removing siphon standpipe.
3. Turn selector switch and start unit; run until compressor goes "off" on high pressure cutout. This will cause the water regulating valve to open fully, permitting water to drain out by gravity.
4. Disconnect flare connection on outlet side of water regulating valve. Some water will drain out.
5. To prevent any trapped water from freezing when unit is not used during winter months, it is necessary to "blow out" the circulating water lines. This may be done by connecting a small refrigerant Freon drum to the disconnected flare nut. Open refrigerant drum slightly and admit small amount of gas. The gas pressure will blow out the trapped water.
6. Disconnect refrigerant drum; reconnect flare nut to water regulating valve. Leave water supply line disconnected. The unit should be tagged, stating in what condition the machine is left so that next year a service man will know exactly what should be done to start the unit up.
7. The "trapped" water in the main control overflow well should be blown out. Blow through the top of well where the control capillary enters.
8. Remove drain plug from siphon interchanger.
9. Make sure disconnect switch is in "off" position. Remove the fuses, or otherwise disconnect the power supply.
10. After a long period of shut down or upon original installation, Ice Cube Makers should be observed through two complete cycles before the mechanic leaves the job.



SERVICE

26H

ICE MAKER SERVICE CHECK LIST

NAME _____ DATE _____

ADDRESS _____

MODEL _____ SERIAL _____ LOCATION OF BUILDING _____

1. Quality of cubes Shells _____ Normal _____ Sticks _____

2. Run time Freeze _____ min. Defrost _____ min. Over-run _____ min.

3. All controls operate satisfactorily.

Main Control Yes ____ No ____

Safety Overflow Yes ____ No ____

Bin Thermostat Yes ____ No ____

High Pressure Cut-Out Yes ____ No ____

4. Tested for leaks

Refrigerant Yes ____ No ____

Water Yes ____ No ____

Oil Yes ____ No ____

5. Evidence of refrigerant and/or water lines rubbing Yes ____ No ____

6. Siphon standpipe operates properly Yes ____ No ____

7. Plastic curtain (does it allow water to splash into bunker?) Yes ____ No ____

8. Crusher operates satisfactorily Yes ____ No ____



SERVICE ANALYSIS 26H5 AND 26H3

UNIT WILL NOT OPERATE

OBSERVATION	POSSIBLE CAUSE	REMEDY AND REFERENCE	SECTIONS
1. Compressor and water pump will not start.	Power off	Check main switch, fuses and wiring	22
	Low voltage	Check building circuit and voltage at main panel	6 & 20
	Loose electrical connections or faulty wiring	Check wiring	20 & 27
	Bin thermostat capillary broken	Examine control bulb and replace if broken	28
	Faulty selector switch	Repair or replace	22
	Off-on safety switch	Check for ice in tubes	
	High pressure switch and bin control contacts open	Check for low ambient temperature, incorrect setting, faulty switch, ice on bulb	30 & 31
2. Compressor and water pump cycle intermittently	This is normal at start up	Start and stop machine at 2-minute intervals several times	Installation 19
	Condenser may be plugged or dirty High pressure switch has opened circuit	Clean condenser; high pressure switch should open at 175 psig head pressure. Minimum water pressure 20 psi. Check water supply.	5,9, & 31
	Plugged capillary	List evaporator shroud; check for frosting of evaporator tubing coil. Replace accumulator assembly which includes capillaries	7 & 10
3. Compressor Cycles - water pump runs.	Low voltage	Voltage should be within plus or minus 10% of nameplate voltage	Installation 13
		Minimum low voltages are 104V for the 115V unit and 207V for the 230V unit	
	Defective starting relay	Check wiring and operation. Replace if necessary	20 & 25
	Overload switch cycles Compressor	Determine cause of overload, may be dirty condenser. Normal for 26H3 compressor on start-up	9
	Compressor motor shorted	Replace compressor	6

OBSERVATION	POSSIBLE CAUSE	REMEDY AND REFERENCE	SECTIONS
4. Compressor runs- water pump is off.	Faulty selector switch	Repair or replace	22
	Pump motor inoperative or out on pump motor overload	Check wiring and voltage. Check with test cord. Repair or replace pump and motor assembly.	17
	Failure of main control to energize pump motor contacts	Replace control	28
5. Water pump runs - compressor off.	Overload switch has opened circuit	Check compressor overload	26
	Selector switch on "pump"	Turn to "on" position	Installation Fig. 17
	Faulty selector switch	Replace selector switch	22
	Compressor motor burned out	Replace compressor motor	6
6. Water pump runs - compressor hums	Loose terminals	Check and tighten	21
	Compressor stuck	Replace	6
	Faulty relay (opened)	Check and replace	25
	Faulty starting capacitor	Check and replace	24

ERRATIC OPERATION

7. Unit will not operate continuously - blowing fuses.	Compressor motor faulty	Replace compressor motor	6
	Low voltage	Check voltage and external wiring	20 & Installation 13
	Faulty ice crusher motor	Repair at motor vendor service station; repair or replace motor.	27
8. Long Freezing Cycle (30-40 minutes, normal).	Surrounding air temperature high and warm supply water temperature	Max air temp 100F. Max water temp 90F.	Installation 2
	Faulty compressor	Repair or replace	6
	Leaky solenoid valve	Turn unit on and off several times to try to seat valve. Check wiring for possible grounded coil. Replace if necessary.	32
	Float valve set too high	Water level should be 3/8 from the top of the siphon standpipe on the 26H3 and 1/2" from the top of the siphon standpipe on the 26H5	Installation 16 Service 11

OBSERVATION	POSSIBLE CAUSE	REMEDY AND REFERENCE	SECTIONS
8. Long Freezing Cycle (30-40 min. normal)	Siphon standpipe is poorly seated, allowing cold water to escape	Check water pan standpipe for proper seating	Installation 16
	Float valve leaking making siphon during freezing period.	Check water pressure. If over 60 psig use a pressure reducing valve and replace if necessary	Installation 12 & 16
9. Long Defrost Cycle (Normal 5 to 8 Minutes)	Main control set incorrectly ("cut-in" temperature too high)	Lower "cut-in" setting	28
	Low-refrigerant charge	Check charge and correct if necessary	4
	Low head pressure during the freezing cycle	Should be 125 psi. Adjust water regulating valve	5 & 13
	Bulged freezing columns	Replace evaporator; check main control	10
	Solenoid valve stuck shut or only partly open (listen for hissing)	Check solenoid and wiring	32
	Leaky water regulating valve	Check and replace if necessary	13
	Water condenser scaled up	Clean condenser with inhibited acid	9
10. During harvest cycle unit switches back to freezing then again to defrost	Defective interlock in main control	Replace	28
	Cut-in Bulb loose on suct. line	Tighten clamps	28
11. Continuous running - no ice formed.	No make up water reaching water pan	Check for stuck float valve or plugged nozzle	11
	Loss of refrigerant	Check refrigerant charge; eliminate any leaks, add refrigerant	4
	Moisture in system	Change dryer	8
	Solenoid valve stuck open	Check for grounded solenoid. Replace if necessary	32
	Float setting too high causing standpipe to siphon	Reset float valve. Seat water pan standpipe	Installation 16 Service 11



SERVICE

26H

OBSERVATION	POSSIBLE CAUSE	REMEDY AND REFERENCE	SECTIONS
12. Continuous running and freezing	Faulty main control, or well capillary scaled	Replace if necessary	28
		Check main control capillary position in well	28
		Replace if ice does not actuate control from freezing cycle to defrost cycle when held against main control capillary (cut-out) side	28
	Overflow water not reaching overflow well and main control bulb	Scale and foreign particles may plug overflow trough tube. Check position of control bulb. Also check leveling of machine	15 & 28
13. Unit fails to return to freeze cycle	Main control "cut-in" bulb has lost its charge	Replace main control	28
	Low ambient temperature	Unit will not operate at ambient temperatures below 50°	Installation 2
14. Unit continues to run with full bunker.	Bin control contacts fused	Replace control	30
	Cutout setting too low	Adjust and check	30
	Ice not reaching bin control bulb		
15. Water overflowing from machine section	Loose electrical connections		
	Main control, safety overflow switch or bin control failed to stop freezing cycle	Check wiring and possibility of faulty controls	28-29 & 30
	Leak in water pump circuit	Check water hoses and header	11 & 12

UNSATISFACTORY CUBES

16. Thin wall cubes "shells".	Manually shutting unit off during a freezing cycle	Normal as a result of such a shut-down. Instruct owner to wait until end of defrost cycle before shutting off unit	18
	Short defrost cycle (cubes remaining in freezing columns)	Check main control setting; may require raising cut in point	28
Check refrigerant charge		4	
Check safety switch		27	

OBSERVATION	POSSIBLE CAUSE	REMEDY AND REFERENCE	SECTIONS
	Plugged capillary, either due to moisture, dirt or crimped capillary	Purge charge; install new strainer-drier. If capillary is damaged, replace accumulator assembly (includes capillaries)	3, 7 & 8
	Cubes "hanging-up" on ice deflector screen	Reposition deflector screen Examine evaporator for warped or bulged freezing columns	Installation 17 10
	Bin thermostat "cut-out" setting may be too high	Adjust and check	30 Installation 2
	Poor water distribution due to scale on spreader plates and/or clogged screen on water pump	Recenter spreader plates and water header nozzles Clean water circuit, including water pan and water pump screen	10, 12 & 15 15
	Low refrigerant charge	Check charge and time of freezing cycle	4
17. Irregular shaped cubes, or mixture of good and shell cubes.	Evaporator tubing pulled loose from freezing columns	Replace evaporator	10
	Cubes restricting one or more columns	Examine deflector screen and ice columns, remove obstructions Raise main control "cut-in" setting slightly (this will increase defrost time)	Installation 15 28
	Float valve set too high. Standpipe not seated	Reset float valve; check for leaky float valve. Seat standpipe properly.	Installation 16
	Bin thermostat prematurely cuts off unit	Check for a faulty bin thermostat; check settings	30
	Temporary power failure during "freezing cycle"	Turn unit "off", permit ice to melt out of columns; start unit when power is restored	
	Cubes hanging up in columns due to bulged tubes	Check freezing columns. Replace evaporator if columns are bulged	10

OBSERVATION	POSSIBLE CAUSE	REMEDY AND REFERENCE	SECTIONS
17. Irregular shaped cubes, or mixture of good and small cubes. "Sticks" of ice	Improper Feed Through Poor water distribution	Check refrigerant charge Check spreader plates. Descale if necessary	4 Fig. 17
	Safety overflow switch, failed to cutout machine	Adjust or replace	29
18. Cloudy cubes	Poor water distribution	Check spreader plates, water header nozzles and pump circuit for obstructions and scale. Clean system with solvent	12 & 15
	Dirty water supply	Check water piping; clean unit periodically; clean water strainer; install water filter	14
	A cloudy surface is normal while cubes are in storage bin	Cloudy surface will clear when cubes are placed in liquid	
19. Unit does not freeze enough ice per day.	Freezing cycle too long due to high head pressure	Adjust water regulating valve to give 125 psig on 26H5 or 130 psig on 26H3	5 & 13
	Freezing cycle too long due to water siphoning out of water pan	Adjust float valve	11
	"Freezing cycle" too long due to excessive splatter of circulating water into bin	Check for torn plastic curtain or cubes holding plastic curtain out of position	Installation Fig. 14
	"Defrost cycle" too long due to low head pressure	Adjust water reg. valve; check refrigerant charge	4, 5, 13 & 14
	"Defrost cycle" too long due to high cut-in setting of main control	Lower "cut-in" setting main control	28
		Caution: All cubes should drop out before freezing begins. One to one and one half minutes recommended between the dropping of the last cube and the beginning of the freezing cycle.	



26H ICEMAKER RATING TABLES

26H5 ICEMAKER EQUIPPED WITH A 3/4 HP COMPRESSOR USING A SIPHON HEAT INTERCHANGER

Supply Water Temp. °F.	Pounds of Ice Per Day					
	50° D.B.* 46° W.B. **	60° D.B. 56° W.B.	70° D.B. 65° W.B.	80° D.B. 73° W.B.	90° D.B. 77° W.B.	100° D.B. 79° W.B.
50	471	469	467	463	465	460
60	445	444	443	438	437	428
70	419	419	419	417	410	398
80	393	393	394	390	383	368
90	368	369	370	364	356	336

26H5 WATER CONSUMPTION USING A SIPHON HEAT INTERCHANGER

Inlet Water Temp. °F.	Gallons per Hour ***					
	50° D.B. 46° W.B.	60° D.B. 56° W.B.	70° D.B. 65° W.B.	80° D.B. 73° W.B.	90° D.B. 77° W.B.	100° D. B. 79° W.B.
50	19	--	-	-	-	-
60	25	26	28	28	28	-
70	31	31	33	36	39	35
80	-	43	46	48	50	49
90	-	-	-	62	62	70

* D.B. = Dry bulb temperature.

** W.B. = Wet bulb temperature.

26H3 ICEMAKER EQUIPPED WITH A 1/2 HP COMPRESSOR USING A SIPHON HEAT INTERCHANGER

Supply Water Temp. °F.	Pounds of Ice Per Day					
	50° Air*	60° Air	70° Air	80° Air	90° Air	100° Air
50	237	233	228	222	215	205
60	223	219	214	208	200	191
70	209	205	200	194	187	178
80	195	190	186	180	173	164
90	181	177	172	166	160	151

* Dry Bulb, with approximately 70% R.H.



26H3 WATER CONSUMPTION USING A SIPHON HEAT INTERCHANGER

Supply Water Temp. °F.	Gallons Per Hour ***					
	50° Air	60° Air	70° Air	80° Air	90° Air	100° Air
50	12	12	12	12	12	12
60	15	15	15	15	15	15
70	19.2	19.2	19.2	19.2	19.2	19.2
80	27.5	27.5	27.5	27.5	27.5	27.5
90	42	42	42	42	42	42

*** Includes water for condensing, siphoning and ice-making.

- NOTE: 1. Figures are based on a head pressure of 125 to 130 lbs. per sq. in. gauge with 70° water and 70° air, halfway through the freezing cycle.
2. Power consumption, halfway through the freezing cycle, varies from 890 watts with 50° water and 50° air to 980 watts with 90° water and 100° air for 26H5. Power consumption for the 26H3 under the same conditions varies from 565 to 580 watts.

Carrier





SERVICE PARTS

26H

NAME	CAT. NO.	USED ON	
		26H3	26H5
COMPRESSOR MOUNTING GROUP			
Mounting Spring	51H2-1791		4
RELAY & CAPACITOR GROUP			
For Overloads and 26H3 Relay and Capacitor See "Motor-Compressor Group"			
115V Starting Relay	HN61HZ-028		1
115V Starting Capacitor	HC97CZ-256		1
230V Starting Relay	HN61HZ-036		1
230V Starting Capacitor	HC97CZ-050		1
CONTROL GROUP			
Bunker Thermostat Includes Power Elements: High Pressure Cut-Out (1) HK09RA-026 Temp. Control (1) HK09RA-030	HK08RA-030	1	1
Safety Thermostat (Ranco) Ending Serial No. 510093 Starting Serial No. 510094	HH22UK-226 26H5-1851	1 1	1 1
Main Control Thermostat (Ranco)	HH22UK-526	1	1
Rotary Switch	HR56AW-003	1	1
Solenoid Coil 115V	EF19SF-215	1	
Solenoid Coil 115V	EF19SF-210		1
Solenoid Coil 230V	EF19SF-211		1
Solenoid Valve Body	EF19SF-023	1	
Solenoid Valve Body	EF19SF-021		1
MOTOR COMPRESSOR GROUP			
Motor-Compressor Assembly 1/2 HP-115V-1PH-60Cy. Includes: Overload (1) HN68GC-026 Capacitor (1) HC97CM-159 Relay (1) HN61GC-026	26H3-1009	1	



NAME	CAT. NO.	USED ON	
		26H3	26H5
MOTOR COMPRESSOR GROUP (Cont'd.)			
Motor-Compressor Assembly 3/4HP-115V-1PH-60Cy.	26C5-389		1
3/4HP-230V-1PH-60Cy. Includes: Valve Plate & Gasket (1) 51H2-KF-061 Includes: Suct. Valve Reed (2) 51H2-KJ-056 Disch. Valve Reed (2) 51H2-KJ-072 Gasket Set (1) 51H2-KJ-069 Overload 115V (1) HN68GB-025 or Overload 230V (1) HN68GB-027	26C5-399		1
INTERNAL GROUP			
Water Pump 115V 230V	26H5-183 26H5-193	1	1 1
Strainer & Drier	KH41EZ-030	1	1
Float Valve Assembly	EC12LA-026	1	1
Water Reg. Valve	EB31XF-026	1	1
Shut-Off Valve Gasket	DK29GA-051		3
CRUSHER GROUP			
Safety Switch	HR64TA-026	1	1
Ice Crusher	26C5-1079	1	1
Motor 1/6 HP-115/230V, 1PH-60Cy.	HC37AZ-401	1	1
*Toggle Switch Ending Serial No. 26H3-321207, 26H5-320640	HR59BC-002	1	1
*Micro Switch Starting Serial No. 26H3-321208, 26H5-320641	HR64TB-026	1	1
Relay 115V	HR61LB-021	1	1
Relay 230V	HR61LB-022		1
*NOTE: Not interchangeable			